

AZ10LVEL16VS AZ100LVEL16VS

ECL/PECL Differential Receiver with Variable Output Swing

FEATURES

- 250ps Propagation Delay
- High Bandwidth Output Transitions
- Operating Range of 3.0V to 5.5V
- Internal Input Pulldown Resistors
- Functionally Equivalent to ON Semiconductor MC10EL16, MC100EL16 & MC100LVEL16
- Variable Output Swing

PACKAGE AVAILABILITY

PACKAGE	PART NUMBER	MARKING	NOTES
SOIC 8	AZ10LVEL16VSD	AZM10 LV16VS	1,2
SOIC 8	AZ100LVEL16VSD	AZM100 LV16VS	1,2
TSSOP 8	AZ10LVEL16VST	AZT L16VS	1,2
TSSOP 8	AZ100LVEL16VST	AZH L16VS	1,2

- 1 Add R1 at end of part number for 7 inch (1K parts), R2 for 13 inch (2.5K parts) Tape & Reel.
- 2 Date code format: "Y" or "YY" for year followed by "WW" for week on underside of part.

DESCRIPTION

The AZ10/100LVEL16VS is a differential receiver with variable output swing. The LVEL16VS has functionality and output transition times similar to the EL16, with an input that controls the amplitude of the Q/Q outputs.

The operational range of the LVEL16VS control input, V_{CTRL} , is from V_{BB} (full swing) to V_{CC} (min. swing). Maximum swing is achieved by leaving the V_{CTRL} pin open or by tying it to the negative supply (V_{EE}). Simple control of the output swing can be obtained by a variable resistor between the V_{BB} and V_{CC} pins, with the wiper driving V_{CTRL} . Typical application circuits and results are described in this Data Sheet.

The LVEL16VS provides a V_{BB} output for single-ended use or a DC bias reference for AC coupling to the device. For single-ended input applications, the V_{BB} reference should be connected to one side of the D/D differential input pair. The input signal is then fed to the other D/D input. The V_{BB} pin can support 1.5mA sink/source current. When used, the V_{BB} pin should be bypassed to ground via a 0.01 μ F capacitor.

Under open input conditions internal input clamps will force the Q output LOW.

NOTE: Specifications in the ECL/PECL tables are valid when thermal equilibrium is established.

PIN DESCRIPTION

PIN	FUNCTION
D, \bar{D}	Data Inputs
V_{CTRL}	Output Swing Control
Q, \bar{Q}	Data Outputs
V_{BB}	Reference Voltage Output
V_{CC}	Positive Supply
V_{EE}	Negative Supply

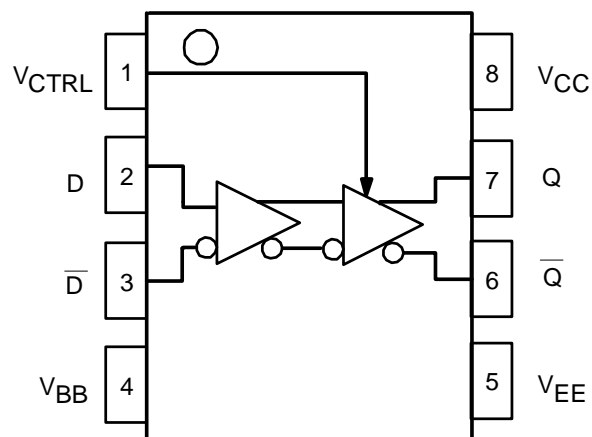

LOGIC DIAGRAM AND PINOUT ASSIGNMENT

AZ10LVEL16VS

AZ100LVEL16VS

Absolute Maximum Ratings are those values beyond which device life may be impaired.

Symbol	Characteristic	Rating	Unit
V_{CC}	PECL Power Supply ($V_{EE} = 0V$)	0 to +8.0	Vdc
V_i	PECL Input Voltage ($V_{EE} = 0V$)	0 to +6.0	Vdc
V_{EE}	ECL Power Supply ($V_{CC} = 0V$)	-8.0 to 0	Vdc
V_i	ECL Input Voltage ($V_{CC} = 0V$)	-6.0 to 0	Vdc
I_{OUT}	Output Current --- Continuous --- Surge	50 100	mA
T_A	Operating Temperature Range	-40 to +85	°C
T_{STG}	Storage Temperature Range	-65 to +150	°C

10K ECL DC Characteristics ($V_{EE} = -3.0V$ to $-5.5V$, $V_{CC} = GND$)

Symbol	Characteristic	-40°C			0°C			25°C			85°C			Unit
		Min	Typ	Max	Min	Typ	Max	Min	Typ	Max	Min	Typ	Max	
V_{OH}	Output HIGH Voltage ²	-1080		-890	-1020		-840	-980		-810	-910		-720	mV
V_{OL}	Output LOW Voltage ² $V_{CTRL} = V_{BB}^1$	-1950		-1650	-1950		-1630	-1950		-1630	-1950		-1595	mV
V_{OL}	Output LOW Voltage ² $V_{CTRL} = V_{CC}$	-1220		-1030	-1200		-1020	-1190		-1150	-1020		-1000	mV
V_{IH}	Input HIGH Voltage	-1230		-890	-1170		-840	-1130		-810	-1060		-720	mV
V_{IL}	Input LOW Voltage	-1950		-1500	-1950		-1480	-1950		-1480	-1950		-1445	mV
V_{BB}	Reference Voltage	-1450		-1300	-1400		-1270	-1370		-1250	-1330		-1190	mV
I_{IH}	Input HIGH Current D, D V_{CTRL}			150 40			150 40			150 40			150 40	μA
I_{IL}	Input LOW Current D, D V_{CTRL}	-150 0.5			-150 0.5			-150 0.5			-150 0.5			μA
I_{EE}	Power Supply Current		18	25		18	25		18	25		21	26	mA

1. If V_{CTRL} is Open Circuit, use the V_{OH} (Max & Min) and V_{OL} ($V_{CTRL} = V_{BB}$: Max only) limits.
2. Each output is terminated through a 50Ω resistor to $V_{CC} - 2V$.

10K LVPECL DC Characteristics ($V_{EE} = GND$, $V_{CC} = +3.3V$)

Symbol	Characteristic	-40°C			0°C			25°C			85°C			Unit
		Min	Typ	Max	Min	Typ	Max	Min	Typ	Max	Min	Typ	Max	
V_{OH}	Output HIGH Voltage ^{1,3}	2220		2410	2280		2460	2320		2490	2390		2580	mV
V_{OL}	Output LOW Voltage ^{1,3} $V_{CTRL} = V_{BB}^2$	1350		1650	1350		1670	1350		1670	1350		1705	mV
V_{OL}	Output LOW Voltage ^{1,3} $V_{CTRL} = V_{CC}$	2080		2270	2100		2280	2110		2280	2110		2300	mV
V_{IH}	Input HIGH Voltage ¹	2070		2410	2130		2460	2170		2490	2240		2580	mV
V_{IL}	Input LOW Voltage ¹	1350		1800	1350		1820	1350		1820	1350		1855	mV
V_{BB}	Reference Voltage ¹	1850		2000	1900		2030	1930		2050	1970		2110	mV
I_{IH}	Input HIGH Current D, D V_{CTRL}			150 40			150 40			150 40			150 40	μA
I_{IL}	Input LOW Current D, D V_{CTRL}	-150 0.5			-150 0.5			-150 0.5			-150 0.5			μA
I_{EE}	Power Supply Current		18	25		18	25		18	25		21	26	mA

1. For supply voltages other than 3.3V, use the ECL table values and ADD supply voltage value.
2. If V_{CTRL} is Open Circuit, use the V_{OH} (Max & Min) and V_{OL} ($V_{CTRL} = V_{BB}$: Max only) limits.
3. Each output is terminated through a 50Ω resistor to $V_{CC} - 2V$.

AZ10LVEL16VS

AZ100LVEL16VS

10K PECL DC Characteristics ($V_{EE} = \text{GND}$, $V_{CC} = +5.0\text{V}$)

Symbol	Characteristic	-40°C			0°C			25°C			85°C			Unit
		Min	Typ	Max	Min	Typ	Max	Min	Typ	Max	Min	Typ	Max	
V_{OH}	Output HIGH Voltage ^{1,3}	3920		4110	3980		4160	4020		4190	4090		4280	mV
V_{OL}	Output LOW Voltage ^{1,3} $V_{CTRL} = V_{BB}^2$	3050		3350	3050		3350	3050		3350	3050		3405	mV
V_{OL}	Output LOW Voltage ^{1,3} $V_{CTRL} = V_{CC}$	3780		3970	3800		3980	3810	3850	3980	3810		4000	mV
V_{IH}	Input HIGH Voltage ¹	3770		4110	3830		4160	3870		4190	3940		4280	mV
V_{IL}	Input LOW Voltage ¹	3050		3500	3050		3520	3050		3520	3050		3555	mV
V_{BB}	Reference Voltage ¹	3550		3700	3600		3730	3630		3750	3670		3810	V
I_{IH}	Input HIGH Current D, D V_{CTRL}			150			150			150			150	μA
				40			40			40			40	
I_{IL}	Input LOW Current D, D V_{CTRL}	-150			-150			-150			-150			μA
		0.5			0.5			0.5			0.5			
I_{EE}	Power Supply Current		18	25		18	25		18	25		21	26	mA

- For supply voltages other than 5.0V, use the ECL table values and ADD supply voltage value.
- If V_{CTRL} is Open Circuit, use the V_{OH} (Max & Min) and V_{OL} ($V_{CTRL} = V_{BB}$: Max only) limits.
- Each output is terminated through a 50Ω resistor to $V_{CC} - 2\text{V}$.

100K ECL DC Characteristics ($V_{EE} = -3.0\text{V}$ to -5.5V , $V_{CC} = \text{GND}$)

Symbol	Characteristic	-40°C			0°C			25°C			85°C			Unit
		Min	Typ	Max	Min	Typ	Max	Min	Typ	Max	Min	Typ	Max	
V_{OH}	Output HIGH Voltage ²	-1085	-1005	-880	-1025	-955	-880	-1025	-955	-880	-1025	-955	-880	mV
V_{OL}	Output LOW Voltage ² $V_{CTRL} = V_{BB}^1$	-1890		-1620	-1870		-1680	-1870	-1775	-1680	-1870		-1680	mV
V_{OL}	Output LOW Voltage ² $V_{CTRL} = V_{CC}$	-1180		-975	-1135		-990	-1135	-1065	-990	-1135		-990	mV
V_{IH}	Input HIGH Voltage	-1165		-880	-1165		-880	-1165		-880	-1165		-880	mV
V_{IL}	Input LOW Voltage	-1810		-1475	-1810		-1475	-1810		-1475	-1810		-1475	mV
V_{BB}	Reference Voltage	-1420		-1260	-1420		-1260	-1420		-1260	-1420		-1260	mV
I_{IH}	Input HIGH Current D, D V_{CTRL}			150			150			150			150	μA
				40			40			40			40	
I_{IL}	Input LOW Current D, D V_{CTRL}	-150			-150			-150			-150			μA
		0.5			0.5			0.5			0.5			
I_{EE}	Power Supply Current		18	25		18	25		18	25		21	26	mA

- If V_{CTRL} is Open Circuit, use the V_{OH} (Max & Min) and V_{OL} ($V_{CTRL} = V_{BB}$: Max only) limits.
- Each output is terminated through a 50Ω resistor to $V_{CC} - 2\text{V}$.

100K LVPECL DC Characteristics ($V_{EE} = \text{GND}$, $V_{CC} = +3.3\text{V}$)

Symbol	Characteristic	-40°C			0°C			25°C			85°C			Unit
		Min	Typ	Max	Min	Typ	Max	Min	Typ	Max	Min	Typ	Max	
V_{OH}	Output HIGH Voltage ^{1,3}	2215	2295	2420	2275	2345	2420	2275	2345	2420	2275	2345	2420	mV
V_{OL}	Output LOW Voltage ^{1,3} $V_{CTRL} = V_{BB}^2$	1410		1680	1430		1620	1430	1525	1620	1430		1620	mV
V_{OL}	Output LOW Voltage ^{1,3} $V_{CTRL} = V_{CC}$	2120		2325	2165		2310	2165	2235	2310	2165		2310	mV
V_{IH}	Input HIGH Voltage ¹	2135		2420	2135		2420	2135		2420	2135		2420	mV
V_{IL}	Input LOW Voltage ¹	1490		1825	1490		1825	1490		1825	1490		1825	mV
V_{BB}	Reference Voltage ¹	1880		2040	1880		2040	1880		2040	1880		2040	mV
I_{IH}	Input HIGH Current D, D V_{CTRL}			150			150			150			150	μA
				40			40			40			40	
I_{IL}	Input LOW Current D, D V_{CTRL}	-150			-150			-150			-150			μA
		0.5			0.5			0.5			0.5			
I_{EE}	Power Supply Current		18	25		18	25		18	25		21	26	mA

- For supply voltages other than 3.3V, use the ECL table values and ADD supply voltage value.
- If V_{CTRL} is Open Circuit, use the V_{OH} (Max & Min) and V_{OL} ($V_{CTRL} = V_{BB}$: Max only) limits.
- Each output is terminated through a 50Ω resistor to $V_{CC} - 2\text{V}$.

AZ10LVEL16VS

AZ100LVEL16VS

100K PECL DC Characteristics ($V_{EE} = \text{GND}$, $V_{CC} = +5.0\text{V}$)

Symbol	Characteristic	-40°C			0°C			25°C			85°C			Unit
		Min	Typ	Max	Min	Typ	Max	Min	Typ	Max	Min	Typ	Max	
V_{OH}	Output HIGH Voltage ^{1,3}	3915	3995	4120	3975	4045	4120	3975	4045	4120	3975	4045	4120	mV
V_{OL}	Output LOW Voltage ^{1,3} $V_{CTRL} = V_{BB}^2$	3110		3380	3130		3320	3130	3225	3320	3130		3320	mV
V_{OL}	Output LOW Voltage ^{1,3} $V_{CTRL} = V_{CC}$	3820		4025	3865		4010	3865	3935	4010	3865		4010	mV
V_{IH}	Input HIGH Voltage ¹	3820		4025	3865		4010	3865	3935	4010	3865		4010	mV
V_{IL}	Input LOW Voltage ¹	3835		4120	3835		4120	3835		4120	3835		4120	mV
V_{BB}	Reference Voltage ¹	3580		3740	3580		3740	3580		3740	3580		3740	V
I_{IH}	Input HIGH Current D, D V_{CTRL}			150 40			150 40			150 40			150 40	μA
I_{IL}	Input LOW Current D, D V_{CTRL}	-150 0.5			-150 0.5			-150 0.5			-150 0.5			μA
I_{EE}	Power Supply Current		18	25		18	25		18	25		21	26	mA

- For supply voltages other than 5.0V, use the ECL table values and ADD supply voltage value.
- If V_{CTRL} is Open Circuit, use the V_{OH} (Max & Min) and V_{OL} ($V_{CTRL} = V_{BB}$: Max only) limits.
- Each output is terminated through a 50 Ω resistor to $V_{CC} - 2\text{V}$.

AC Characteristics ($V_{EE} = -3.0\text{V}$ to -5.5V ; $V_{CC} = \text{GND}$; $V_{CTRL} = V_{BB}$ or $V_{EE} = \text{GND}$; $V_{CC} = +3.0\text{V}$ to $+5.5\text{V}$; $V_{CTRL} = V_{BB}$)

Symbol	Characteristic	-40°C			0°C			25°C			85°C			Unit
		Min	Typ	Max	Min	Typ	Max	Min	Typ	Max	Min	Typ	Max	
t_{PLH} / t_{PHL}	Input to (DIFF) Output Delay (SE)		250		175	250	325	175	250	325	205	280	355	ps
t_{SKEW}	Duty Cycle Skew ¹ (Diff)		5		5	5	20	5	5	20	5	5	20	ps
$V_{PP}(\text{AC})$	Minimum Input Swing ²	150			150			150			150			mV
V_{CMR}	Common Mode Range ³ $V_{PP} < 500\text{mV}$ $V_{PP} \geq 500\text{mV}$	$V_{EE} +$ 1.2 1.5		$V_{CC} -$ 0.4 0.4	$V_{EE} +$ 1.1 1.4		$V_{CC} -$ 0.4 0.4	$V_{EE} +$ 1.1 1.4		$V_{CC} -$ 0.4 0.4	$V_{EE} +$ 1.1 1.4		$V_{CC} -$ 0.4 0.4	V
t_r / t_f	Output Rise/Fall Times Q (20% - 80%)	100		260	100		260	100		260	100		260	ps

- Duty cycle skew is the difference between a t_{PLH} and t_{PHL} propagation delay through a device.
- V_{PP} is the minimum peak-to-peak differential input swing for which AC parameters are guaranteed.
- The V_{CMR} range is referenced to the most positive side of the differential input signal. Normal operation is obtained if the HIGH level falls within the specified range and the peak-to-peak voltage lies between $V_{PP}(\text{min})$ and 1V.

AZ10LVEL16VS
AZ100LVEL16VS

Typical Voltage Output Swing at +25C, V_{CC} Nom (see Figure 1 and Figure 2)

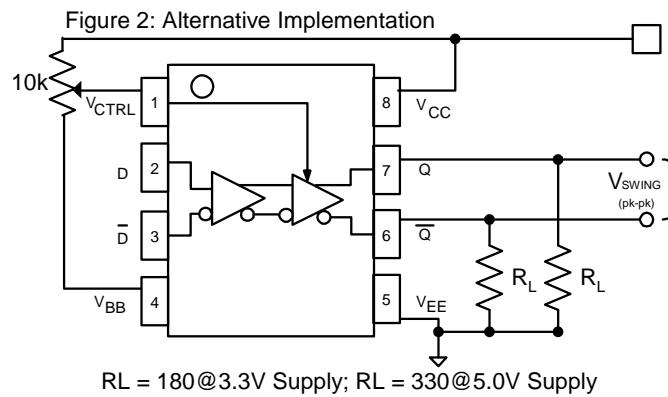
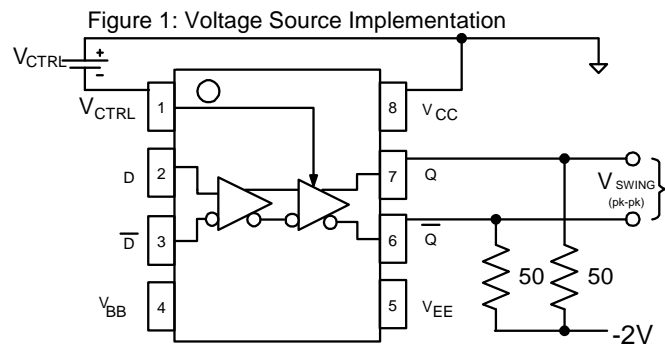
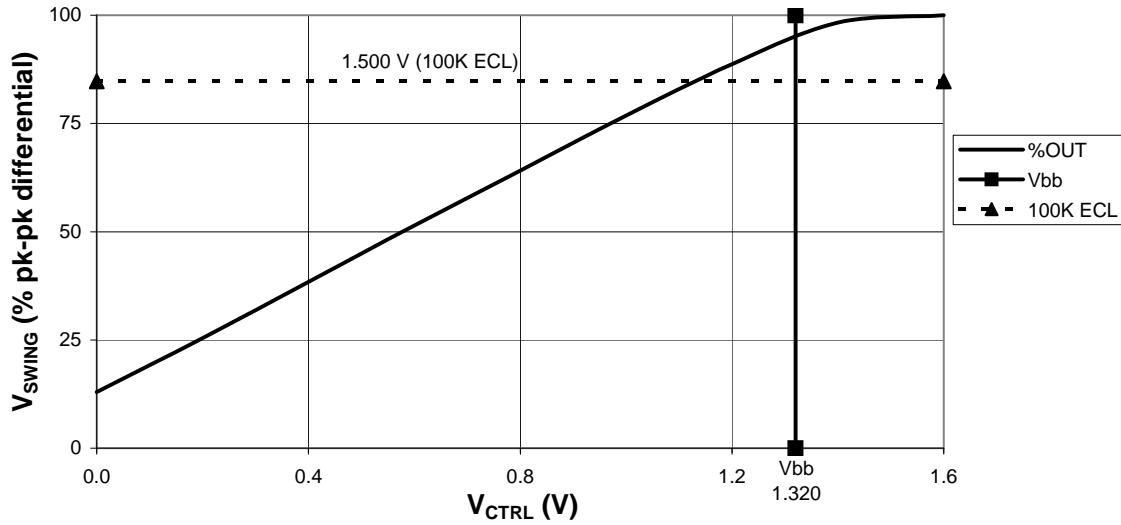

**PACKAGE DIAGRAM
SOIC 8**

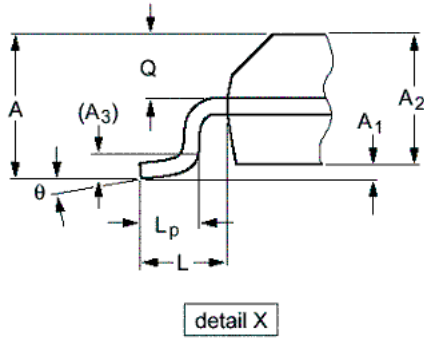
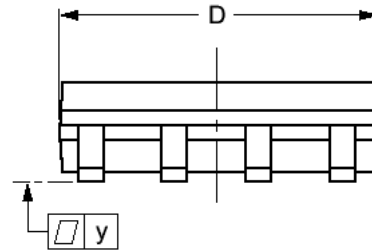
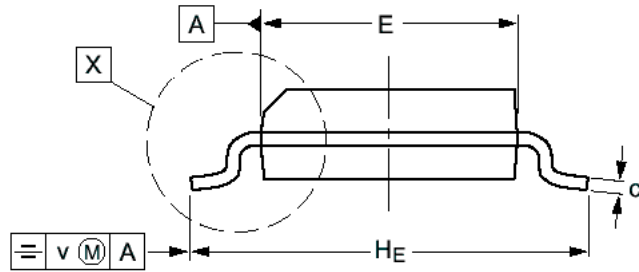
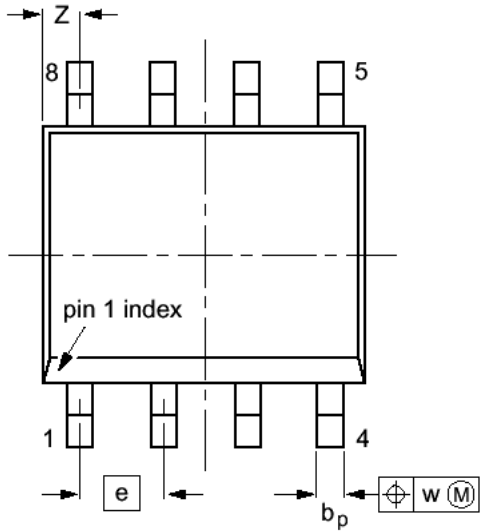

DIM	MILLIMETERS		INCHES	
	MIN	MAX	MIN	MAX
A		1.75		0.069
A ₁	0.10	0.25	0.004	0.010
A ₂	1.25	1.45	0.049	0.057
A ₃	0.25		0.01	
b _p	0.36	0.49	0.014	0.019
c	0.19	0.25	0.0075	0.0100
D	4.8	5.0	0.19	0.20
E	3.8	4.0	0.15	0.16
e	1.27		0.050	
H _E	5.80	6.20	0.228	0.244
L	1.05		0.041	
L _p	0.40	1.00	0.016	0.039
Q	0.60	0.70	0.024	0.028
v	0.25		0.01	
w	0.25		0.01	
y	0.10		0.004	
Z	0.30	0.70	0.012	0.028
θ	0°	8°	0°	8°

NOTES:

1. DIMENSIONS D AND E DO NOT INCLUDE MOLD PROTRUSION.
2. MAXIMUM MOLD PROTRUSION FOR D IS 0.15mm.
3. MAXIMUM MOLD PROTRUSION FOR E IS 0.25mm.

AZ10LVEL16VS
AZ100LVEL16VS

PACKAGE DIAGRAM
TSSOP 8

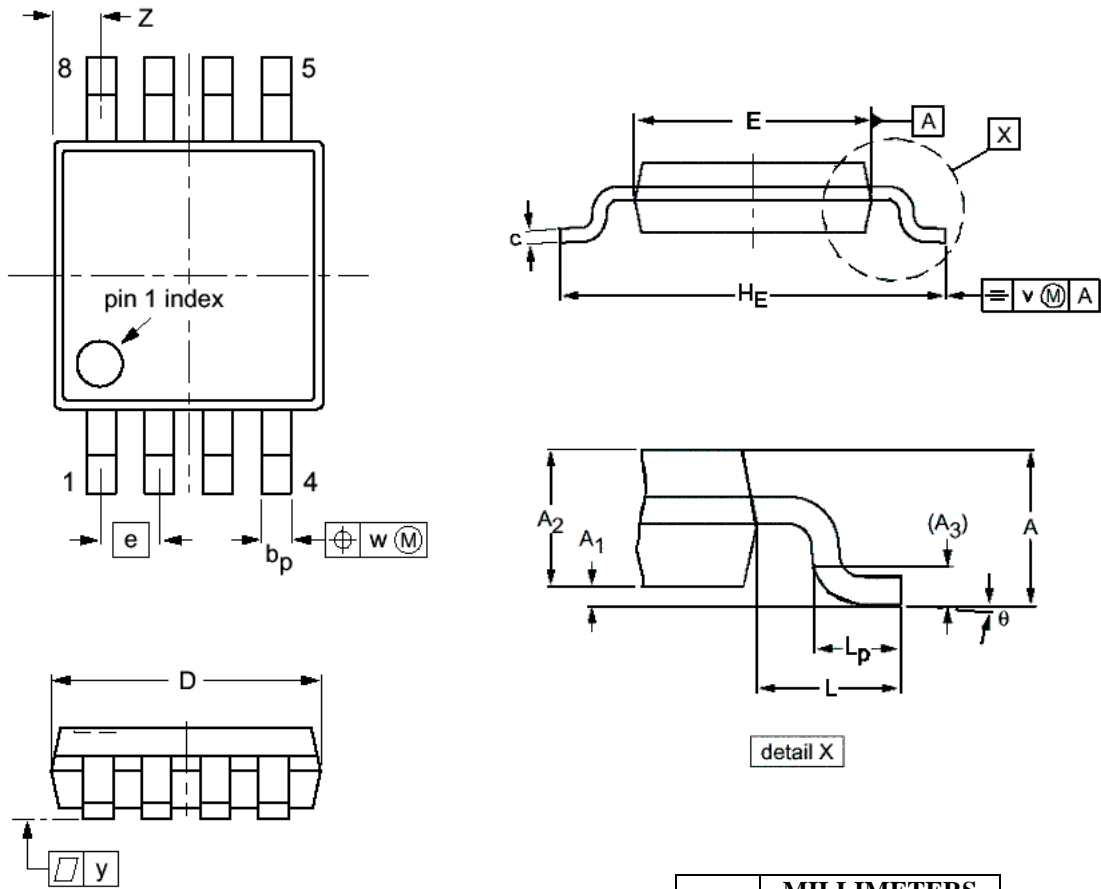

- NOTES:
1. DIMENSIONS D AND E DO NOT INCLUDE MOLD PROTRUSION.
 2. MAXIMUM MOLD PROTRUSION FOR D IS 0.15mm.
 3. MAXIMUM MOLD PROTRUSION FOR E IS 0.25mm.

DIM	MILLIMETERS	
	MIN	MAX
A		1.10
A₁	0.05	0.15
A₂	0.80	0.95
A₃	0.25	
b_p	0.25	0.45
c	0.15	0.28
D	2.90	3.10
E	2.90	3.10
e	0.65	
H_E	4.70	5.10
L	0.94	
L_p	0.40	0.70
v	0.10	
w	0.10	
y	0.10	
Z	0.35	0.70
θ	0°	6°

AZ10LVEL16VS
AZ100LVEL16VS

Arizona Microtek, Inc. reserves the right to change circuitry and specifications at any time without prior notice. Arizona Microtek, Inc. makes no warranty, representation or guarantee regarding the suitability of its products for any particular purpose, nor does Arizona Microtek, Inc. assume any liability arising out of the application or use of any product or circuit and specifically disclaims any and all liability, including without limitation special, consequential or incidental damages. Arizona Microtek, Inc. does not convey any license rights nor the rights of others. Arizona Microtek, Inc. products are not designed, intended or authorized for use as components in systems intended to support or sustain life, or for any other application in which the failure of the Arizona Microtek, Inc. product could create a situation where personal injury or death may occur. Should Buyer purchase or use Arizona Microtek, Inc. products for any such unintended or unauthorized application, Buyer shall indemnify and hold Arizona Microtek, Inc. and its officers, employees, subsidiaries, affiliates, and distributors harmless against all claims, costs, damages, and expenses, and reasonable attorney fees arising out of, directly or indirectly, any claim of personal injury or death associated with such unintended or unauthorized use, even if such claim alleges that Arizona Microtek, Inc. was negligent regarding the design or manufacture of the part.