

# AZ100LVE310

## ECL/PECL 2:8 Differential Clock Driver

### FEATURES

- Operating Range of 3.0V to 5.5V
- Low Skew
- Guaranteed Skew Spec
- Differential Design
- $V_{BB}$  Output
- 75k $\Omega$  Internal Input Pulldown Resistors
- Direct Replacement for ON Semiconductor MC100LVE310 & MC100E310

### PACKAGE AVAILABILITY

PACKAGE	PART NUMBER	MARKING	NOTES
PLCC 28	AZ100LVE310FN	AZM100LVE310 <Date Code>	1,2

- 1 Add R2 at end of part number for 13 inch (2.5K parts) Tape & Reel.
- 2 Date code format: "YY" for year followed by "WW" for week.

### DESCRIPTION

The AZ100LVE310 is a low skew 2:8 fanout buffer designed with clock distribution in mind. The device features fully differential clock paths to minimize both device and system skew. The AZ100LVE310 offers two selectable clock inputs allowing redundant or test clocks to be incorporated into the system clock trees.

The AZ100LVE310 provides a  $V_{BB}$  output for single-ended use or a DC bias reference for AC coupling to the device. For single-ended input applications, the  $V_{BB}$  reference should be connected to one side of the CLKa/CLKb differential input pair. The input signal is then fed to the other CLKa/CLKb input. The  $V_{BB}$  pin should be used only as a bias for the AZ100LVE310 as its current sink/source capability is limited. When used, the  $V_{BB}$  pin should be bypassed to ground via a 0.01 $\mu$ F capacitor.

Both sides of the differential output must be terminated into 50 $\Omega$  to ensure that the tight skew specification is met, even if only one side is used. In most applications all eight differential pairs will be used and therefore terminated. In the case where fewer than eight pairs are used, all output pairs on the same package side (sharing the same  $V_{CC0}$ ) as the pairs being used should be terminated to maintain minimum skew. Failure to do this will result in small degradations of propagation delay (on the order of 10–20ps) of the outputs being used; while not being catastrophic to most designs this will result in an increase in skew.

NOTE: Specifications in the ECL/PECL tables are valid when thermal equilibrium is established.

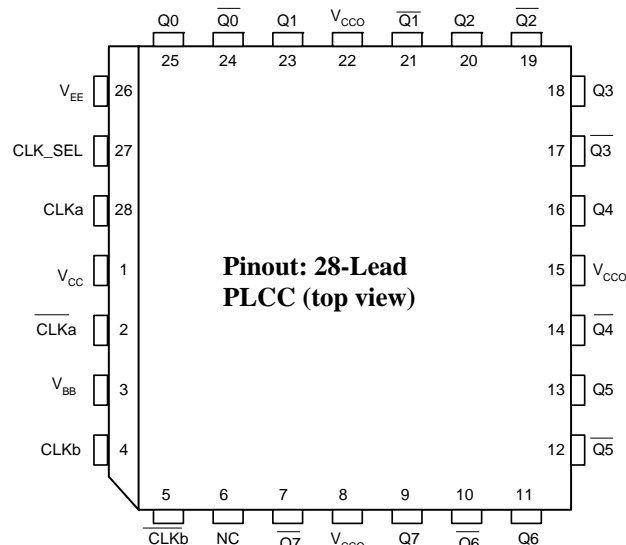

**PIN DESCRIPTION**

PIN	FUNCTION
CLKa, CLK $\bar{a}$	Differential Input Pairs
CLKb, CLK $\bar{b}$	Differential Input Pairs
CLK_SEL	Input Clock Select
Q0, Q $\bar{0}$ – Q7, Q $\bar{7}$	Differential Output Pairs
V <sub>BB</sub>	V <sub>BB</sub> Output
V <sub>CC</sub> , V <sub>CC0</sub>	Positive Supply
V <sub>EE</sub>	Negative Supply
NC	No Connect

CLK_SEL	Input Clock
0	CLKa Selected
1	CLKb Selected

**LOGIC SYMBOL**

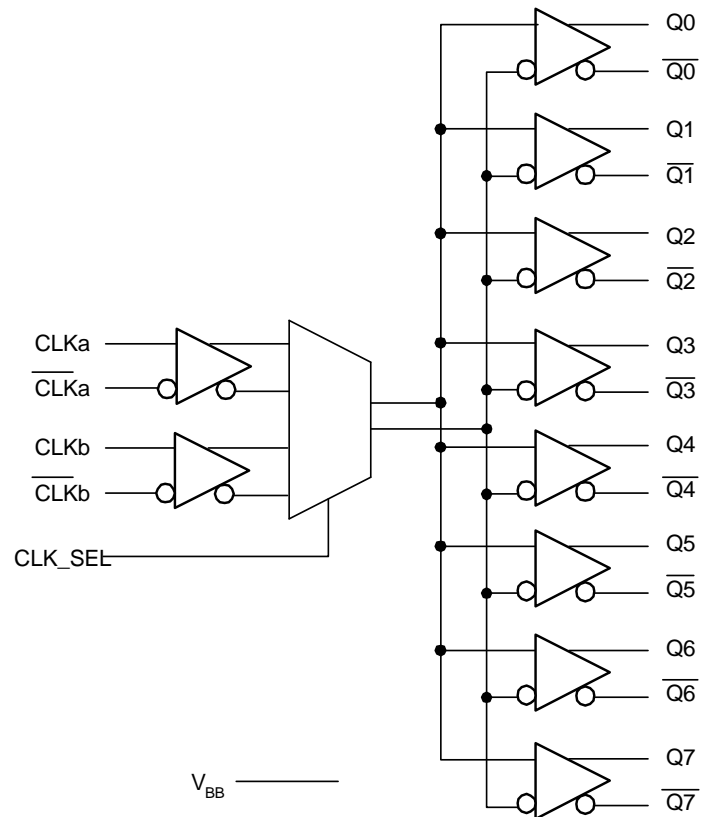

**Absolute Maximum Ratings are those values beyond which device life may be impaired.**

Symbol	Characteristic	Rating	Unit
V <sub>CC</sub>	PECL Power Supply (V <sub>EE</sub> = 0V)	0 to +8.0	Vdc
V <sub>I</sub>	PECL Input Voltage (V <sub>EE</sub> = 0V)	0 to +6.0	Vdc
V <sub>EE</sub>	ECL Power Supply (V <sub>CC</sub> = 0V)	-8.0 to 0	Vdc
V <sub>I</sub>	ECL Input Voltage (V <sub>CC</sub> = 0V)	-6.0 to 0	Vdc
I <sub>OUT</sub>	Output Current --- Continuous --- Surge	50 100	mA
T <sub>A</sub>	Operating Temperature Range	-40 to +85	°C
T <sub>STG</sub>	Storage Temperature Range	-65 to +150	°C

**100K ECL DC Characteristics (V<sub>EE</sub> = -3.0V to -5.5V, V<sub>CC</sub> = V<sub>CC0</sub> = GND)**

Symbol	Characteristic	-40°C			0°C			25°C			85°C			Unit
		Min	Typ	Max	Min	Typ	Max	Min	Typ	Max	Min	Typ	Max	
V <sub>OH</sub>	Output HIGH Voltage <sup>1</sup>	-1085	-1005	-880	-1025	-955	-880	-1025	-955	-880	-1025	-955	-880	mV
V <sub>OL</sub>	Output LOW Voltage <sup>1</sup>	-1830	-1695	-1555	-1810	-1705	-1620	-1810	-1705	-1620	-1810	-1705	-1620	mV
V <sub>IH</sub>	Input HIGH Voltage	-1165		-880	-1165		-880	-1165		-880	-1165		-880	mV
V <sub>IL</sub>	Input LOW Voltage	-1810		-1475	-1810		-1475	-1810		-1475	-1810		-1475	mV
V <sub>BB</sub>	Reference Voltage	-1380		-1260	-1380		-1260	-1380		-1260	-1380		-1260	mV
I <sub>IH</sub>	Input HIGH Current			150			150			150			150	μA
I <sub>IL</sub>	Input LOW Current	0.5			0.5			0.5			0.5			μA
I <sub>EE</sub>	Power Supply Current		55	60		55	60		55	60		65	70	mA

1. Each output is terminated through a 50Ω resistor to V<sub>CC</sub> - 2V.

# AZ100LVE310

## 100K LVPECL DC Characteristics ( $V_{EE} = \text{GND}$ , $V_{CC} = V_{CCO} = +3.3\text{V}$ )

Symbol	Characteristic	-40°C			0°C			25°C			85°C			Unit
		Min	Typ	Max	Min	Typ	Max	Min	Typ	Max	Min	Typ	Max	
$V_{OH}$	Output HIGH Voltage <sup>1,2</sup>	2215	2295	2420	2275	2345	2420	2275	2345	2420	2275	2345	2420	mV
$V_{OL}$	Output LOW Voltage <sup>1,2</sup>	1470	1605	1745	1490	1595	1680	1490	1595	1680	1490	1595	1680	mV
$V_{IH}$	Input HIGH Voltage <sup>1</sup>	2135		2420	2135		2420	2135		2420	2135		2420	mV
$V_{IL}$	Input LOW Voltage <sup>1</sup>	1490		1825	1490		1825	1490		1825	1490		1825	mV
$V_{BB}$	Reference Voltage <sup>1</sup>	1920		2040	1920		2040	1920		2040	1920		2040	mV
$I_{IH}$	Input HIGH Current			150			150			150			150	μA
$I_{IL}$	Input LOW Current	0.5			0.5			0.5			0.5			μA
$I_{EE}$	Power Supply Current		55	60		55	60		55	60		65	70	mA

- For supply voltages other than 3.3V, use the ECL table values and ADD supply voltage value.
- Each output is terminated through a 50Ω resistor to  $V_{CC} - 2\text{V}$ .

## 100K PECL DC Characteristics ( $V_{EE} = \text{GND}$ , $V_{CC} = V_{CCO} = +5.0\text{V}$ )

Symbol	Characteristic	-40°C			0°C			25°C			85°C			Unit
		Min	Typ	Max	Min	Typ	Max	Min	Typ	Max	Min	Typ	Max	
$V_{OH}$	Output HIGH Voltage <sup>1,2</sup>	3915	3995	4120	3975	4045	4120	3975	4045	4120	3975	4045	4120	mV
$V_{OL}$	Output LOW Voltage <sup>1,2</sup>	3170	3305	3445	3190	3295	3380	3190	3295	3380	3190	3295	3380	mV
$V_{IH}$	Input HIGH Voltage <sup>1</sup>	3835		4120	3835		4120	3835		4120	3835		4120	mV
$V_{IL}$	Input LOW Voltage <sup>1</sup>	3190		3525	3190		3525	3190		3525	3190		3525	mV
$V_{BB}$	Reference Voltage <sup>1</sup>	3620		3740	3620		3740	3620		3740	3620		3740	mV
$I_{IH}$	Input HIGH Current			150			150			150			150	μA
$I_{IL}$	Input LOW Current	0.5			0.5			0.5			0.5			μA
$I_{EE}$	Power Supply Current		55	60		55	60		55	60		65	70	mA

- For supply voltages other than 5.0V, use the ECL table values and ADD supply voltage value.
- Each output is terminated through a 50Ω resistor to  $V_{CC} - 2\text{V}$ .

## AC Characteristics ( $V_{EE} = -3.0\text{V}$ to $-5.5\text{V}$ , $V_{CC} = V_{CCO} = \text{GND}$ or $V_{EE} = \text{GND}$ , $V_{CC} = V_{CCO} = +3.0$ to $+5.5\text{V}$ )

Symbol	Characteristic	-40°C			0°C			25°C			85°C			Unit
		Min	Typ	Max	Min	Typ	Max	Min	Typ	Max	Min	Typ	Max	
$t_{PLH} / t_{PHL}$	Propagation Delay to Output IN (Diff) <sup>1</sup> IN (SE) <sup>2</sup>	525		725	550		750	550		750	575		775	ps
$t_{SKEW}$	Within-Device Skew Part-to-Part Skew (Diff) <sup>3</sup>			75			75			50			50	ps
$V_{PP}(\text{AC})$	Minimum Input Swing <sup>4</sup>	250			250			250			250			mV
$V_{CMR}$	Common Mode Range <sup>5</sup>	$V_{EE} + 1.8$		$V_{CC} - 0.4$	$V_{EE} + 1.8$		$V_{CC} - 0.4$	$V_{EE} + 1.8$		$V_{CC} - 0.4$	$V_{EE} + 1.8$		$V_{CC} - 0.4$	V
$t_r / t_f$	Rise/Fall Time 20 – 80%	250	450	650	275	375	600	275	375	600	275	375	600	ps

- The differential propagation delay is defined as the delay from the crossing point of the differential input signals to the crossing point of the differential output signals.
- The single-ended propagation delay is defined as the delay from the 50% point of the input signal to the 50% point of the output signal.
- The within-device skew is defined as the worst-case difference between any two similar delay paths within a single device.
- $V_{PP}$  is the minimum peak-to-peak differential input swing for which AC parameters are guaranteed. The  $V_{PP}(\text{min})$  is AC limited for the LVE310, because differential input as low as 50 mV will still produce full ECL levels at the output.
- $V_{CMR}$  is defined as the range within which the  $V_{IH}$  level may vary, with the device still meeting the propagation delay specification. The  $V_{IL}$  level must be such that the peak-to-peak voltage is less than 1.0V and greater than or equal to  $V_{PP}(\text{min})$ .

**PACKAGE DIAGRAM  
PLCC 28**

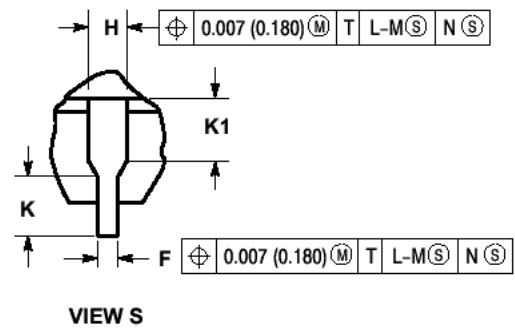
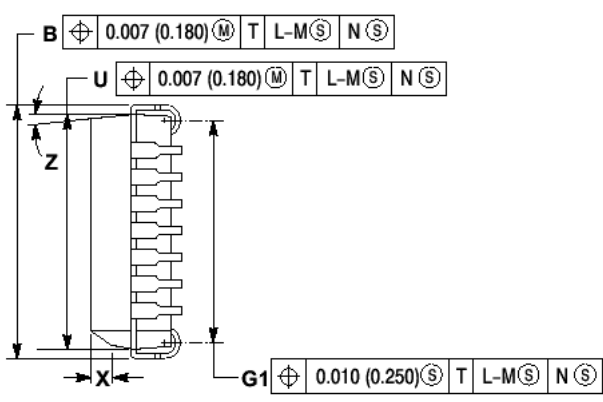
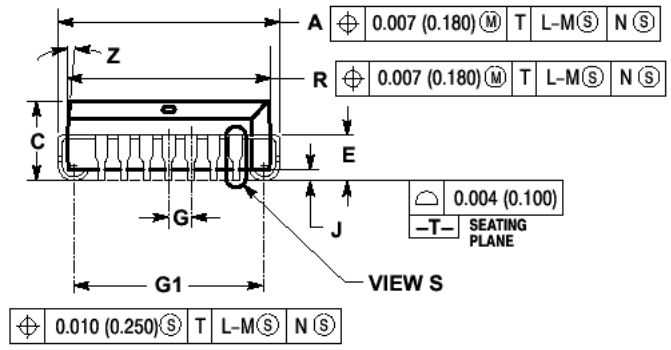
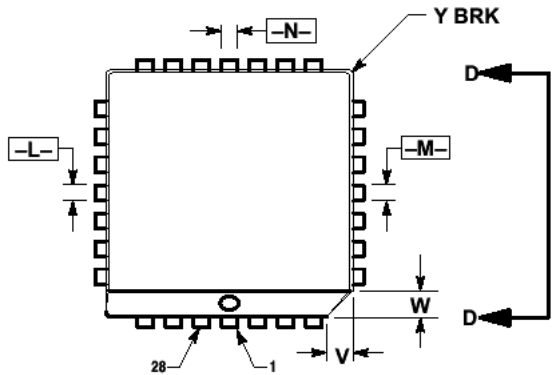

VIEW D-D

VIEW S

DIM	MILLIMETERS		INCHES	
	MIN	MAX	MIN	MAX
A	12.32	12.57	0.485	0.495
B	12.32	12.57	0.485	0.495
C	4.20	4.57	0.165	0.180
E	2.29	2.79	0.090	0.110
F	0.33	0.48	0.013	0.019
G	1.27 BSC		0.050 BSC	
H	0.66	0.81	0.026	0.032
J	0.51		0.020	
K	0.64		0.025	
R	11.43	11.58	0.450	0.456
U	11.43	11.58	0.450	0.456
V	1.07	1.21	0.042	0.048
W	1.07	1.21	0.042	0.048
X	1.07	1.42	0.042	0.056
T		0.50		0.020
Z	2°	10°	2°	10°
G1	10.42	10.92	0.410	0.430
K1	1.02		0.040	

NOTES:

- DATUMS -L-, -M-, AND -N- DETERMINED WHERE TOP OF LEAD SHOULDER EXITS PLASTIC BODY AT MOLD PARTING LINE.
- DIMENSION G1, TRUE POSITION TO BE MEASURED AT DATUM -T-, SEATING PLANE.
- DIMENSIONS R AND U DO NOT INCLUDE MOLD FLASH. ALLOWABLE MOLD FLASH IS 0.010mm (0.250in.) PER SIDE.
- DIMENSIONING AND TOLERANCING PER ANSI Y14.5M, 1982.
- CONTROLLING DIMENSION: INCH.
- THE PACKAGE TOP MAY BE SMALLER THAN THE PACKAGE BOTTOM BY UP TO 0.012mm (0.300in.). DIMENSIONS R AND U ARE DETERMINED AT THE OUTERMOST EXTREMES OF THE PLASTIC BODY EXCLUSIVE OF MOLD FLASH, THE BAR BURRS, GATE BURRS AND INTERLEAD FLASH, BUT INCLUDING ANY MISMATCH BETWEEN THE TOP AND BOTTOM OF THE PLASTIC BODY.
- DIMENSION H DOES NOT INCLUDE DAMBAR PROTRUSION OR INTRUSION. THE DAMBAR PROTRUSION(S) SHALL NOT CAUSE THE H DIMENSION TO BE SMALLER THAN 0.025mm (0.635in.).

Arizona Microtek, Inc. reserves the right to change circuitry and specifications at any time without prior notice. Arizona Microtek, Inc. makes no warranty, representation or guarantee regarding the suitability of its products for any particular purpose, nor does Arizona Microtek, Inc. assume any liability arising out of the application or use of any product or circuit and specifically disclaims any and all liability, including without limitation special, consequential or incidental damages. Arizona Microtek, Inc. does not convey any license rights nor the rights of others. Arizona Microtek, Inc. products are not designed, intended or authorized for use as components in systems intended to support or sustain life, or for any other application in which the failure of the Arizona Microtek, Inc. product could create a situation where personal injury or death may occur. Should Buyer purchase or use Arizona Microtek, Inc. products for any such unintended or unauthorized application, Buyer shall indemnify and hold Arizona Microtek, Inc. and its officers, employees, subsidiaries, affiliates, and distributors harmless against all claims, costs, damages, and expenses, and reasonable attorney fees arising out of, directly or indirectly, any claim of personal injury or death associated with such unintended or unauthorized use, even if such claim alleges that Arizona Microtek, Inc. was negligent regarding the design or manufacture of the part.