

AZ10EL89

ECL/PECL Coaxial Cable Driver

FEATURES

- 375ps Propagation Delay
- 1.6V Output Swing
- Internal Input Pulldown Resistors
- Operating Range of 4.2V to 5.7V
- Direct Replacement for ON Semiconductor MC10EL89
- Transistor Count = 29 devices

PACKAGE AVAILABILITY

PACKAGE	PART NUMBER	MARKING	NOTES
SOIC 8	AZ10EL89D	AZM10EL89	1,2

- 1 Add R1 at end of part number for 7 inch (1K parts), R2 for 13 inch (2.5K parts) Tape & Reel.
- 2 Date Code "YWW" on underside of part.

DESCRIPTION

The AZ10EL89 is a differential fanout gate specifically designed to drive coaxial cables. The device is especially useful in Digital Video Broadcasting applications. For this application, since the system is polarity free, each output can be used as an independent driver. The driver has a voltage gain of approximately 40 and produces an output swing twice as large as standard ECL output. When driving a coaxial cable, proper termination is required at both ends of the line to minimize signal loss. The 1.6 V output swing allows for termination at both ends of the cable, while maintaining the required 800 mV swing at the receiving end of the cable. Because of the larger output swings, the device cannot be terminated into the standard $V_{CC} - 2.0V$. All of the DC parameters are tested with a 50Ω to $V_{CC} - 3.0V$ load. The driver accepts a standard differential ECL input and can run off of the Digital Video Broadcast standard $-5.0V$ supply. Under open input conditions (pulled to V_{EE}) internal input clamps will force the Qn output LOW.

NOTE: Specifications in ECL/PECL tables are valid when thermal equilibrium is established.

LOGIC DIAGRAM AND PINOUT ASSIGNMENT

PIN DESCRIPTION

PIN	FUNCTION
D, \bar{D}	Data Inputs
Q0, $\bar{Q}0$, Q1, $\bar{Q}1$	Data Outputs (1.6V _{pp})
V_{CC}	Positive Supply
V_{EE}	Negative Supply

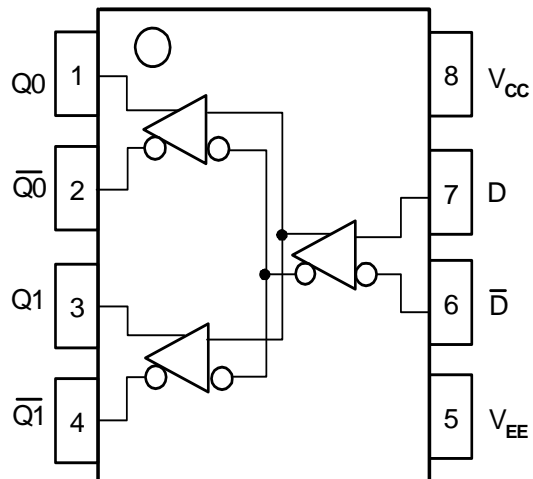

AZ10EL89

Absolute Maximum Ratings are those values beyond which device life may be impaired.

Symbol	Characteristic	Rating	Unit
V _{CC}	PECL Power Supply (V _{EE} = 0V)	0 to +8.0	Vdc
V _I	PECL Input Voltage (V _{EE} = 0V)	0 to +6.0	Vdc
V _{EE}	ECL Power Supply (V _{CC} = 0V)	-8.0 to 0	Vdc
V _I	ECL Input Voltage (V _{CC} = 0V)	-6.0 to 0	Vdc
I _{OUT}	Output Current --- Continuous --- Surge	50 100	mA
T _A	Operating Temperature Range	-40 to +85	°C
T _{STG}	Storage Temperature Range	-65 to +150	°C

10K ECL DC Characteristics (V_{EE} = -4.2V to -5.7V, V_{CC} = GND)

Symbol	Characteristic	-40°C			0°C			25°C			85°C			Unit
		Min	Typ	Max	Min	Typ	Max	Min	Typ	Max	Min	Typ	Max	
V _{OH}	Output HIGH Voltage ¹	-1230		-980	-1180		-940	-1130		-900	-1060		-810	mV
V _{OL}	Output LOW Voltage ¹	-2900		-2580	-2950		-2570	-3000		-2560	-3050		-2510	mV
V _{IH}	Input HIGH Voltage	-1230		-890	-1170		-840	-1130		-810	-1060		-720	mV
V _{IL}	Input LOW Voltage	-1950		-1500	-1950		-1480	-1950		-1480	-1950		-1445	mV
I _{IL}	Input LOW Current	0.5			0.5			0.5			0.5			μA
I _{IH}	Input HIGH Current			150			150			150			150	μA
I _{EE}	Power Supply Current		23	28		23	28		23	28		23	28	mA

- Each output is terminated through a 50Ω resistor to V_{CC} - 3V.

10K PECL DC Characteristics (V_{EE} = GND, V_{CC} = +5.0V)

Symbol	Characteristic	-40°C			0°C			25°C			85°C			Unit
		Min	Typ	Max	Min	Typ	Max	Min	Typ	Max	Min	Typ	Max	
V _{OH}	Output HIGH Voltage ^{1,2}	3770		4020	3820		4060	3870		4100	3940		4190	mV
V _{OL}	Output LOW Voltage ^{1,2}	2100		2420	2050		2430	2000		2440	1950		2490	mV
V _{IH}	Input HIGH Voltage ¹	3770		4110	3830		4160	3870		4190	3940		4280	mV
V _{IL}	Input LOW Voltage ¹	3050		3500	3050		3520	3050		3520	3050		3555	mV
I _{IL}	Input LOW Current	0.5			0.5			0.5			0.5			μA
I _{IH}	Input HIGH Current			150			150			150			150	μA
I _{EE}	Power Supply Current		23	28		23	28		23	28		23	28	mA

- For supply voltages other than 5.0V, use the ECL table values and ADD supply voltage value.
- Each output is terminated through a 50Ω resistor to V_{CC} - 3V.

AC Characteristics (V_{EE} = -4.2V to -5.7V, V_{CC} = GND or V_{EE} = GND, V_{CC} = +4.2V to +5.7V)

Symbol	Characteristic	-40°C			0°C			25°C			85°C			Unit
		Min	Typ	Max	Min	Typ	Max	Min	Typ	Max	Min	Typ	Max	
t _{max}	Maximum Toggle Rate								1.5					Gb/s
t _{PLH} / t _{PHL}	Propagation Delay to Output	200	340	480	250	340	430	260	350	440	310	400	490	ps
t _{SKEW}	Within-Device Skew ¹ Duty Cycle Skew ²		5	20		5	20		5	20		5	20	ps
V _{PP} (AC)	Minimum Input Swing ³	150			150			150			150			mV
V _{CMR}	Common Mode Range ⁴	V _{EE} + 2.5		V _{CC} - 0.4	V _{EE} + 2.5		V _{CC} - 0.4	V _{EE} + 2.5		V _{CC} - 0.4	V _{EE} + 2.5		V _{CC} - 0.4	V
t _r / t _f	Output Rise/Fall Times Q (20% - 80%)	205		455	205		455	205		455	205		455	ps

- Within-device skew defined as identical transitions on similar paths through a device.
- Duty cycle skew is the difference between a t_{PLH} and t_{PHL} propagation delay through a device.
- V_{PP} is the minimum peak-to-peak differential input swing for which AC parameters guaranteed. The device has a DC gain of ≈ 40.
- The V_{CMR} range is referenced to the most positive side of the differential input signal. Normal operation is obtained if the HIGH level falls within the specified range and the peak-to-peak voltage lies between V_{PP} (min) and 1V.

**PACKAGE DIAGRAM
SOIC 8**

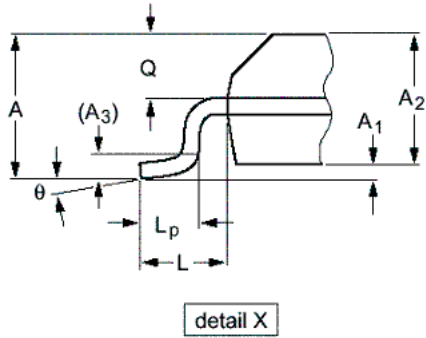
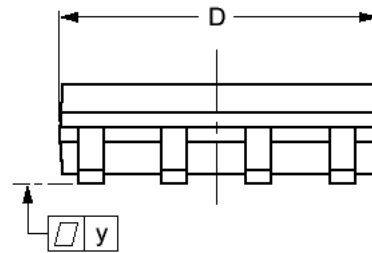
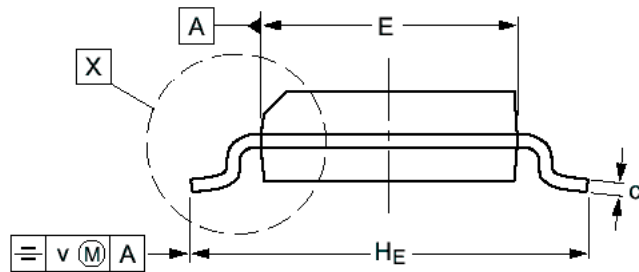
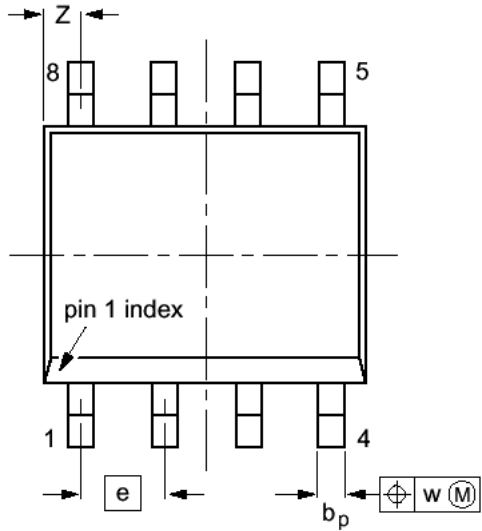

DIM	MILLIMETERS		INCHES	
	MIN	MAX	MIN	MAX
A		1.75		0.069
A ₁	0.10	0.25	0.004	0.010
A ₂	1.25	1.45	0.049	0.057
A ₃	0.25		0.01	
b _p	0.36	0.49	0.014	0.019
c	0.19	0.25	0.0075	0.0100
D	4.8	5.0	0.19	0.20
E	3.8	4.0	0.15	0.16
e	1.27		0.050	
H _E	5.80	6.20	0.228	0.244
L	1.05		0.041	
L _p	0.40	1.00	0.016	0.039
Q	0.60	0.70	0.024	0.028
v	0.25		0.01	
w	0.25		0.01	
y	0.10		0.004	
Z	0.30	0.70	0.012	0.028
θ	0°	8°	0°	8°

NOTES:

1. DIMENSIONS D AND E DO NOT INCLUDE MOLD PROTRUSION.
2. MAXIMUM MOLD PROTRUSION FOR D IS 0.15mm.
3. MAXIMUM MOLD PROTRUSION FOR E IS 0.25mm.

Arizona Microtek, Inc. reserves the right to change circuitry and specifications at any time without prior notice. Arizona Microtek, Inc. makes no warranty, representation or guarantee regarding the suitability of its products for any particular purpose, nor does Arizona Microtek, Inc. assume any liability arising out of the application or use of any product or circuit and specifically disclaims any and all liability, including without limitation special, consequential or incidental damages. Arizona Microtek, Inc. does not convey any license rights nor the rights of others. Arizona Microtek, Inc. products are not designed, intended or authorized for use as components in systems intended to support or sustain life, or for any other application in which the failure of the Arizona Microtek, Inc. product could create a situation where personal injury or death may occur. Should Buyer purchase or use Arizona Microtek, Inc. products for any such unintended or unauthorized application, Buyer shall indemnify and hold Arizona Microtek, Inc. and its officers, employees, subsidiaries, affiliates, and distributors harmless against all claims, costs, damages, and expenses, and reasonable attorney fees arising out of, directly or indirectly, any claim of personal injury or death associated with such unintended or unauthorized use, even if such claim alleges that Arizona Microtek, Inc. was negligent regarding the design or manufacture of the part.