

# AZ10EL32 AZ100EL32

## ECL/PECL ÷ 2 Divider

### FEATURES

- 510ps Propagation Delay
- 3.0GHz Toggle Frequency
- High Bandwidth Output Transitions
- 75k $\Omega$  Internal Input Pulldown Resistors
- Direct Replacement for ON Semiconductor MC10EL32 & MC100EL32

### PACKAGE AVAILABILITY

PACKAGE	PART NUMBER	MARKING	NOTES
SOIC 8	AZ10EL32D	AZM10 EL32	1,2
SOIC 8	AZ100EL32D	AZM100 EL32	1,2
SOIC 8 RoHS Compliant / Lead (Pb) Free	AZ100EL32D+	AZM100+ EL32	1,2
TSSOP 8	AZ10EL32T	AZT EL32	1,2
TSSOP 8	AZ100LVEL32T	AZH EL32	1,2

- 1 Add R1 at end of part number for 7 inch (1K parts), R2 for 13 inch (2.5K parts) Tape & Reel.
- 2 Date code format: "Y" or "YY" for year followed by "WW" for week on underside of part.

### DESCRIPTION

The AZ10/100EL32 is an integrated  $\div 2$  divider. The reset pin is asynchronous and is asserted on the rising edge. Upon power-up, the internal flip-flop will attain a random logic state; the reset allows for the synchronization of multiple EL32's in a system.

The EL32 provides a  $V_{BB}$  output for single-ended use or a DC bias reference for AC coupling to the device. For single-ended input applications, the  $V_{BB}$  reference should be connected to one side of the CLK/CLK differential input pair. The input signal is then fed to the other CLK/CLK input. The  $V_{BB}$  pin should be used only as a bias for the EL32 as its sink/source capability is limited. When used, the  $V_{BB}$  pin should be bypassed to ground via a 0.01 $\mu$ F capacitor.

NOTE: Specifications in ECL/PECL tables are valid when thermal equilibrium is established.

### LOGIC DIAGRAM AND PINOUT ASSIGNMENT

#### PIN DESCRIPTION

PIN	FUNCTION
CLK, CLK	Clock Inputs
RESET	Asynchronous Reset
$V_{BB}$	Reference Voltage Output
Q, Q	Data Outputs
$V_{CC}$	Positive Supply
$V_{EE}$	Negative Supply

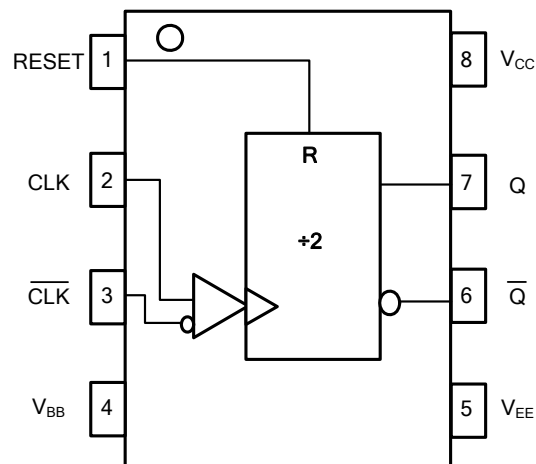

**AZ10EL32**  
**AZ100EL32**

**Absolute Maximum Ratings are those values beyond which device life may be impaired.**

Symbol	Characteristic	Rating	Unit
V <sub>CC</sub>	PECL Power Supply (V <sub>EE</sub> = 0V)	0 to +8.0	Vdc
V <sub>I</sub>	PECL Input Voltage (V <sub>EE</sub> = 0V)	0 to +6.0	Vdc
V <sub>EE</sub>	ECL Power Supply (V <sub>CC</sub> = 0V)	-8.0 to 0	Vdc
V <sub>I</sub>	ECL Input Voltage (V <sub>CC</sub> = 0V)	-6.0 to 0	Vdc
I <sub>OUT</sub>	Output Current --- Continuous --- Surge	50 100	mA
T <sub>A</sub>	Operating Temperature Range	-40 to +85	°C
T <sub>STG</sub>	Storage Temperature Range	-65 to +150	°C

**10K ECL DC Characteristics (V<sub>EE</sub> = -4.75V to -5.5V, V<sub>CC</sub> = GND)**

Symbol	Characteristic	-40°C			0°C			25°C			85°C			Unit
		Min	Typ	Max	Min	Typ	Max	Min	Typ	Max	Min	Typ	Max	
V <sub>OH</sub>	Output HIGH Voltage <sup>1</sup>	-1080		-890	-1020		-840	-980		-810	-910		-720	mV
V <sub>OL</sub>	Output LOW Voltage <sup>1</sup>	-1950		-1650	-1950		-1630	-1950		-1630	-1950		-1595	mV
V <sub>IH</sub>	Input HIGH Voltage	-1230		-890	-1170		-840	-1130		-810	-1060		-720	mV
V <sub>IL</sub>	Input LOW Voltage	-1950		-1500	-1950		-1480	-1950		-1480	-1950		-1445	mV
I <sub>IH</sub>	Input HIGH Current			150			150			150			150	μA
I <sub>IL</sub>	Input LOW Current	0.5			0.5			0.5			0.5			μA
V <sub>BB</sub>	Output Reference Voltage	-1430		-1300	-1380		-1270	-1350		-1250	-1310		-1190	mV
I <sub>EE</sub>	Power Supply Current		25	30		25	30		25	30		25	30	mA

- Each output is terminated through a 50Ω resistor to V<sub>CC</sub> - 2V.

**10K PECL DC Characteristics (V<sub>EE</sub> = GND, V<sub>CC</sub> = +5.0V)**

Symbol	Characteristic	-40°C			0°C			25°C			85°C			Unit
		Min	Typ	Max	Min	Typ	Max	Min	Typ	Max	Min	Typ	Max	
V <sub>OH</sub>	Output HIGH Voltage <sup>1,2</sup>	3920		4110	3980		4160	4020		4190	4090		4280	mV
V <sub>OL</sub>	Output LOW Voltage <sup>1,2</sup>	3050		3350	3050		3370	3050		3370	3050		3405	mV
V <sub>IH</sub>	Input HIGH Voltage <sup>1</sup>	3770		4110	3830		4160	3870		4190	3940		4280	mV
V <sub>IL</sub>	Input LOW Voltage <sup>1</sup>	3050		3500	3050		3520	3050		3520	3050		3555	mV
I <sub>IH</sub>	Input HIGH Current			150			150			150			150	μA
I <sub>IL</sub>	Input LOW Current	0.5			0.5			0.5			0.5			μA
V <sub>BB</sub>	Output Reference Voltage	3570		3700	3620		3730	3650		3750	3690		3810	mV
I <sub>EE</sub>	Power Supply Current		25	30		25	30		25	30		25	30	mA

- For supply voltages other than 5.0V, use the ECL table values and ADD supply voltage value.
- Each output is terminated through a 50Ω resistor to V<sub>CC</sub> - 2V.

**100K ECL DC Characteristics (V<sub>EE</sub> = -4.2V to -5.5V, V<sub>CC</sub> = GND)**

Symbol	Characteristic	-40°C			0°C			25°C			85°C			Unit
		Min	Typ	Max	Min	Typ	Max	Min	Typ	Max	Min	Typ	Max	
V <sub>OH</sub>	Output HIGH Voltage <sup>1</sup>	-1085	-1005	-880	-1025	-955	-880	-1025	-955	-880	-1025	-955	-880	mV
V <sub>OL</sub>	Output LOW Voltage <sup>1</sup>	-1830	-1695	-1555	-1810	-1705	-1620	-1810	-1705	-1620	-1810	-1705	-1620	mV
V <sub>IH</sub>	Input HIGH Voltage	-1165		-880	-1165		-880	-1165		-880	-1165		-880	mV
V <sub>IL</sub>	Input LOW Voltage	-1810		-1475	-1810		-1475	-1810		-1475	-1810		-1475	mV
I <sub>IH</sub>	Input HIGH Current			150			150			150			150	μA
I <sub>IL</sub>	Input LOW Current	0.5			0.5			0.5			0.5			μA
V <sub>BB</sub>	Output Reference Voltage	-1380		-1260	-1380		-1260	-1380		-1260	-1380		-1260	mV
I <sub>EE</sub>	Power Supply Current		25	30		25	30		25	30		29	35	mA

- Each output is terminated through a 50Ω resistor to V<sub>CC</sub> - 2V.

**AZ10EL32**  
**AZ100EL32**

**100K PECL DC Characteristics** ( $V_{EE} = \text{GND}$ ,  $V_{CC} = +5.0\text{V}$ )

Symbol	Characteristic	-40°C			0°C			25°C			85°C			Unit
		Min	Typ	Max	Min	Typ	Max	Min	Typ	Max	Min	Typ	Max	
$V_{OH}$	Output HIGH Voltage <sup>1,2</sup>	3915	3995	4120	3975	4045	4120	3975	4045	4120	3975	4045	4120	mV
$V_{OL}$	Output LOW Voltage <sup>1,2</sup>	3170	3305	3445	3190	3295	3380	3190	3295	3380	3190	3295	3380	mV
$V_{IH}$	Input HIGH Voltage <sup>1</sup>	3835		4120	3835		4120	3835		4120	3835		4120	mV
$V_{IL}$	Input LOW Voltage <sup>1</sup>	3190		3525	3190		3525	3190		3525	3190		3525	mV
$I_{IH}$	Input HIGH Current			150			150			150			150	μA
$I_{IL}$	Input LOW Current	0.5			0.5			0.5			0.5			μA
$V_{BB}$	Output Reference Voltage	3620		3740	3620		3740	3620		3740	3620		3740	mV
$I_{EE}$	Power Supply Current		25	30		25	30		25	30		29	35	mA

- For supply voltages other than 5.0V, use the ECL table values and ADD supply voltage value.
- Each output is terminated through a 50Ω resistor to  $V_{CC} - 2\text{V}$ .

**AC Characteristics** ( $V_{EE} = 10\text{E}(-4.75\text{V to } -5.5\text{V})$ ,  $100\text{E}(-4.2\text{V to } -5.5\text{V})$ ;  $V_{CC} = \text{GND}$  or  $V_{EE} = \text{GND}$ ,  $V_{CC} = 10\text{E}(+4.75\text{V to } +5.5\text{V})$ ,  $100\text{E}(+4.2\text{V to } +5.5\text{V})$ )

Symbol	Characteristic	-40°C			0°C			25°C			85°C			Unit
		Min	Typ	Max	Min	Typ	Max	Min	Typ	Max	Min	Typ	Max	
$f_{\text{max}}$	Maximum Toggle Frequency	2.2	3.0		2.6	3.0		2.6	3.0		2.6	3.0		GHz
$t_{\text{PLH}}/t_{\text{PHL}}$	Propagation Delay CLK to Q Reset to Q	360 390	500 540	640 690	410 440	500 540	590 640	420 440	510 540	600 640	450 450	540 550	630 650	ps
$V_{\text{PP}}(\text{AC})$	Minimum Input Swing <sup>1</sup>	150			150			150			150			mV
$V_{\text{CMR}}$	Common Mode Range <sup>2</sup>	$V_{\text{CC}} - 2.5$		$V_{\text{CC}} - 0.4$	$V_{\text{CC}} - 2.5$		$V_{\text{CC}} - 0.4$	$V_{\text{CC}} - 2.5$		$V_{\text{CC}} - 0.4$	$V_{\text{CC}} - 2.5$		$V_{\text{CC}} - 0.4$	V
$t_r / t_f$	Output Rise/Fall Times Q (20% - 80%)	100		350	100		350	100		350	100		350	ps

- $V_{\text{PP}}$  is the minimum peak-to-peak differential input swing for which AC parameters are guaranteed.
- $V_{\text{CMR}}$  is defined as the range within which the  $V_{\text{IH}}$  level may vary, with the device still meeting the propagation delay specification. The  $V_{\text{IL}}$  level must be such that the peak-to-peak voltage is less than 1.0V and greater than or equal to  $V_{\text{PP}}(\text{min})$ .

**Figure 1: Timing Diagram**

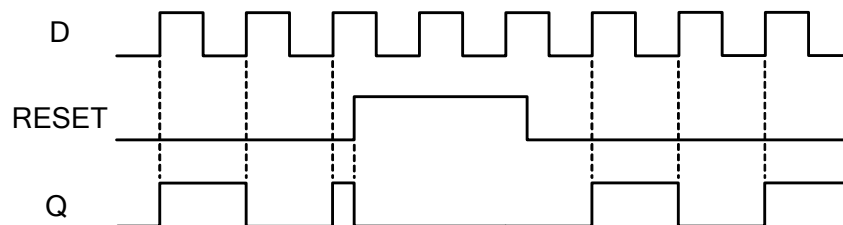

**PACKAGE DIAGRAM  
SOIC 8**

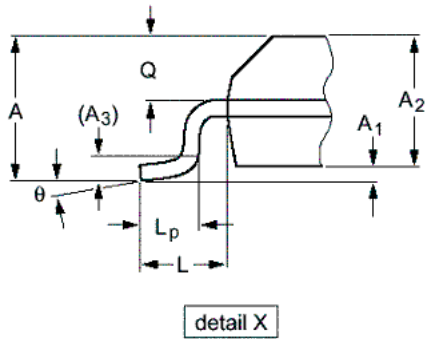
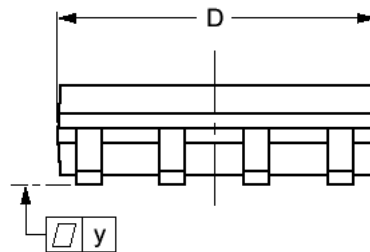
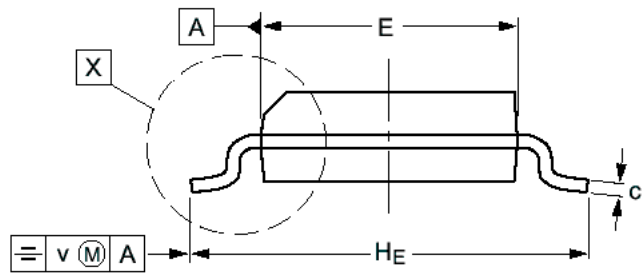
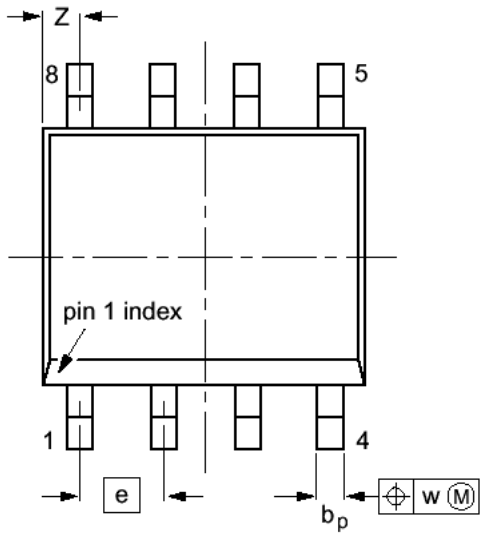

DIM	MILLIMETERS		INCHES	
	MIN	MAX	MIN	MAX
A		1.75	0.069	
A <sub>1</sub>	0.10	0.25	0.004	0.010
A <sub>2</sub>	1.25	1.45	0.049	0.057
A <sub>3</sub>	0.25		0.01	
b <sub>p</sub>	0.36	0.49	0.014	0.019
c	0.19	0.25	0.0075	0.0100
D	4.8	5.0	0.19	0.20
E	3.8	4.0	0.15	0.16
e	1.27		0.050	
H <sub>E</sub>	5.80	6.20	0.228	0.244
L	1.05		0.041	
L <sub>p</sub>	0.40	1.00	0.016	0.039
Q	0.60	0.70	0.024	0.028
v	0.25		0.01	
w	0.25		0.01	
y	0.10		0.004	
Z	0.30	0.70	0.012	0.028
θ	0°	8°	0°	8°

**NOTES:**

1. DIMENSIONS D AND E DO NOT INCLUDE MOLD PROTRUSION.
2. MAXIMUM MOLD PROTRUSION FOR D IS 0.15mm.
3. MAXIMUM MOLD PROTRUSION FOR E IS 0.25mm.

**PACKAGE DIAGRAM  
TSSOP 8**

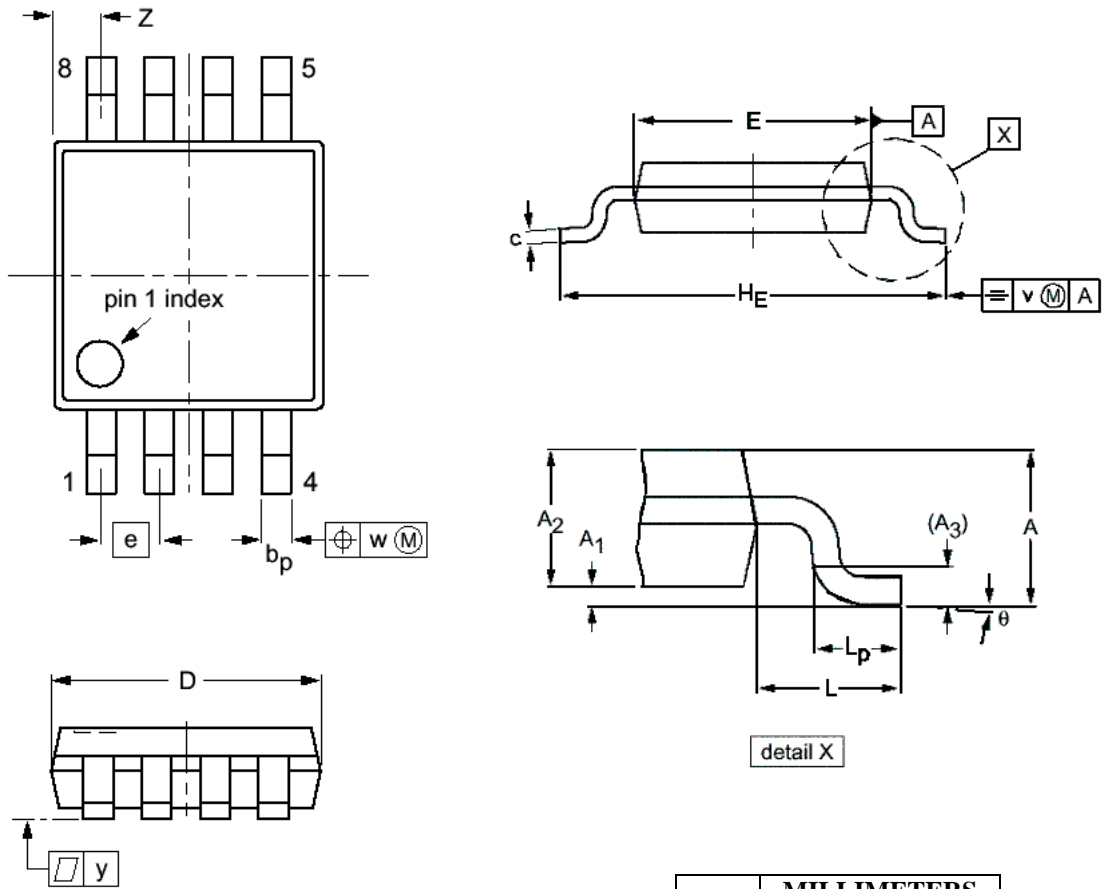

- NOTES:
1. DIMENSIONS D AND E DO NOT INCLUDE MOLD PROTRUSION.
  2. MAXIMUM MOLD PROTRUSION FOR D IS 0.15mm.
  3. MAXIMUM MOLD PROTRUSION FOR E IS 0.25mm.

DIM	MILLIMETERS	
	MIN	MAX
A		1.10
A <sub>1</sub>	0.05	0.15
A <sub>2</sub>	0.80	0.95
A <sub>3</sub>	0.25	
b <sub>p</sub>	0.25	0.45
c	0.15	0.28
D	2.90	3.10
E	2.90	3.10
e	0.65	
H <sub>E</sub>	4.70	5.10
L	0.94	
L <sub>p</sub>	0.40	0.70
v	0.10	
w	0.10	
y	0.10	
Z	0.35	0.70
θ	0°	6°

**AZ10EL32**  
**AZ100EL32**

Arizona Microtek, Inc. reserves the right to change circuitry and specifications at any time without prior notice. Arizona Microtek, Inc. makes no warranty, representation or guarantee regarding the suitability of its products for any particular purpose, nor does Arizona Microtek, Inc. assume any liability arising out of the application or use of any product or circuit and specifically disclaims any and all liability, including without limitation special, consequential or incidental damages. Arizona Microtek, Inc. does not convey any license rights nor the rights of others. Arizona Microtek, Inc. products are not designed, intended or authorized for use as components in systems intended to support or sustain life, or for any other application in which the failure of the Arizona Microtek, Inc. product could create a situation where personal injury or death may occur. Should Buyer purchase or use Arizona Microtek, Inc. products for any such unintended or unauthorized application, Buyer shall indemnify and hold Arizona Microtek, Inc. and its officers, employees, subsidiaries, affiliates, and distributors harmless against all claims, costs, damages, and expenses, and reasonable attorney fees arising out of, directly or indirectly, any claim of personal injury or death associated with such unintended or unauthorized use, even if such claim alleges that Arizona Microtek, Inc. was negligent regarding the design or manufacture of the part.