

AZG489

PECL Video Cable Driver

FEATURES

- 720 Mb/s Typical Data Rate
- 1.6V Typical Output Swing
- Independent Outputs Operate in Phase
- $5V \pm 10\%$ Supply Voltage

PACKAGE AVAILABILITY

PACKAGE	PART NUMBER	MARKING	NOTES
SOIC 8	AZG489D	AZG489 <Date Code>	1,2

- 1 Add R1 at end of part number for 7 inch (1K parts), R2 for 13 inch (2.5K parts) Tape & Reel.
- 2 Date Code "YWW" on underside of part.

DESCRIPTION

The AZG489 is a multiple output cable driver specifically designed to drive coaxial video cables. The device is especially useful in Digital Video Broadcasting applications. Each output has its own output stage and thus each is isolated from the other outputs.

The driver has a voltage gain of approximately 40 and produces an output swing of 1.6 volts, twice as large as a standard PECL output. When driving a coaxial cable, proper termination is required at both ends of the cable to minimize reflections. The 1.6V output signal allows for termination at both ends of the cable, while providing an 800mV signal at the receiving end of the cable.

The driver accepts a standard differential PECL input and can be powered with a 5.0V supply. Under open input conditions internal input clamps will force all outputs HIGH.

Additional power supply filtering is required because of the large amount of in-phase output current. A capacitor (0.1 μ F minimum) must bypass V_{CC} to V_{EE} in close proximity to the AZG489. A ferrite bead (1K Ω @ 100 MHz) must be placed in series to the V_{EE} pin. Additional capacitance may be required based on board layout. See Figure 1 for further information.

NOTE: The specifications in the PECL table are valid when thermal equilibrium is established. The maximum junction temperature is 125°C. Thermal management may be required in some applications to ensure the junction temperature does not exceed that value.

LOGIC DIAGRAM AND PINOUT ASSIGNMENT

PIN DESCRIPTION

PIN	FUNCTION
D, \bar{D}	PECL Data Inputs
Q0, Q1, Q2, Q3	Data Outputs (1.6V _{pp})
V_{CC}	Positive Supply
V_{EE}	Negative Supply

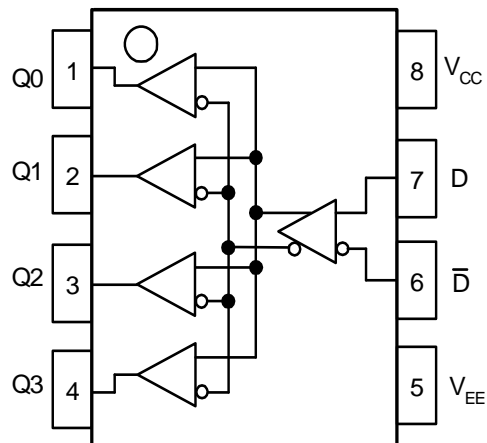

AZG489

Absolute Maximum Ratings are those values beyond which device life may be impaired.

Symbol	Characteristic	Rating	Unit
V_{CC}	PECL Power Supply ($V_{EE} = 0V$)	0 to +8.0	Vdc
V_I	PECL Input Voltage ($V_{EE} = 0V$)	0 to +6.0	Vdc
I_{OUT}	Output Current — Continuous — Surge	50 100	mA
T_A	Operating Temperature Range	-40 to +85	°C
T_{STG}	Storage Temperature Range	-65 to +150	°C

10K PECL DC Characteristics ($V_{EE} = GND, V_{CC} = +5.0V$)

Symbol	Characteristic	-40°C			0°C			25°C			85°C			Unit
		Min	Typ	Max	Min	Typ	Max	Min	Typ	Max	Min	Typ	Max	
V_{OH}	Output HIGH Voltage ¹	3770		4070	3820		4110	3870		4150	3940		4240	mV
V_{OL}	Output LOW Voltage ¹	2000		2420	1950		2430	1900		2440	1850		2490	mV
V_{IH}	Input HIGH Voltage	3770		4110	3830		4160	3870		4190	3940		4280	mV
V_{IL}	Input LOW Voltage	3050		3500	3050		3520	3050		3520	3050		3555	mV
I_{IL}	Input LOW Current	-150			-150			-150			-150			μA
I_{IH}	Input HIGH Current			150			150			150			150	μA
I_{EE}	Power Supply Current			50			50			50			50	mA

- Each output is terminated through a 150Ω resistor to V_{EE} .

AC Characteristics¹ ($V_{EE} = GND, V_{CC} = 5V \pm 10\%$)

Symbol	Characteristic	-40°C			0°C			25°C			85°C			Unit
		Min	Typ	Max	Min	Typ	Max	Min	Typ	Max	Min	Typ	Max	
t_{max}	Maximum Toggle Rate	600			600			600	720		570			Mb/s
t_{PLH} / t_{PHL}	Propagation Delay Input to Output	520		800	520		800	520	660	800	550		900	ps
$V_{PP}(AC)$	Minimum Input Swing ²	150			150			150			150			mV
V_{CMR}	Common Mode Range ³	$V_{EE} + 2.5$		$V_{CC} - 0.4$	$V_{EE} + 2.5$		$V_{CC} - 0.4$	$V_{EE} + 2.5$		$V_{CC} - 0.4$	$V_{EE} + 2.5$		$V_{CC} - 0.4$	V
t_r / t_f	Output Rise/Fall Times Q0 – Q3 (20% – 80%)	295		655	295		655	295		655	295		655	ps

- Each output is terminated through a 150Ω resistor to Ground with an additional AC load of 150Ω to Ground. See Figure 1 for circuit used.
- V_{PP} is the minimum peak-to-peak differential input swing for which AC parameters are guaranteed. The device has a DC gain of ≈ 40 .
- The V_{CMR} range is referenced to the most positive side of the differential input signal. Normal operation is obtained if the HIGH level falls within the specified range and the peak-to-peak voltage lies between V_{PP} (Minimum Input Swing) and 1V.

AZG489

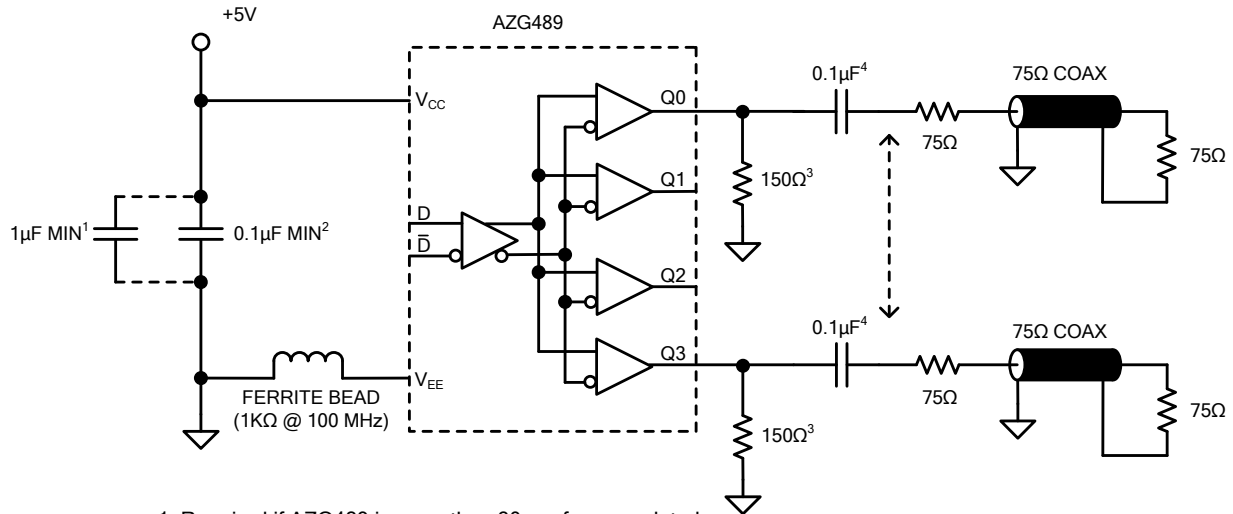

1. Required if AZG489 is more than 30mm from regulated source.
2. Place as close to the AZG489 as possible.
3. DC load resistor value range: 100Ω to 200Ω.
4. Typical values, select as needed for application.

Figure 1. Typical Application

**PACKAGE DIAGRAM
SOIC 8**

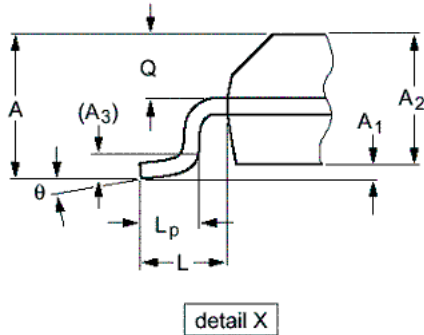
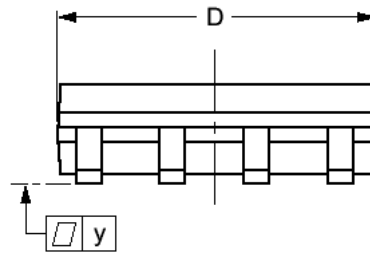
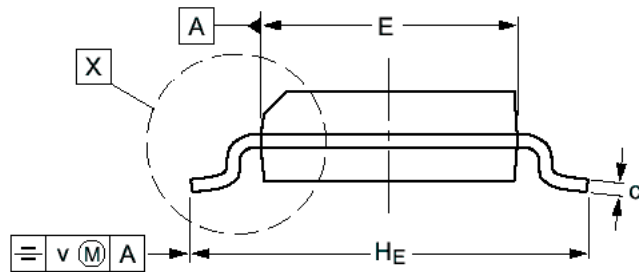
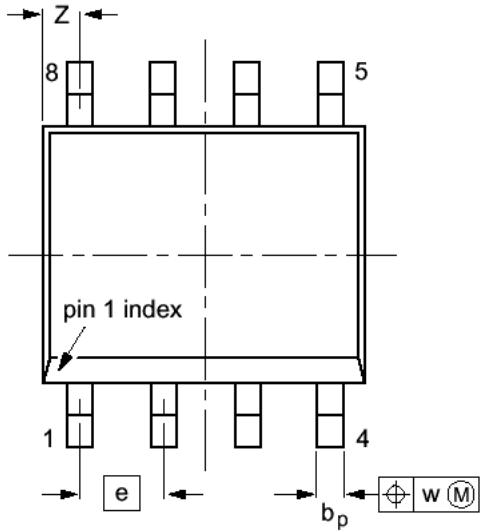

DIM	MILLIMETERS		INCHES	
	MIN	MAX	MIN	MAX
A		1.75		0.069
A ₁	0.10	0.25	0.004	0.010
A ₂	1.25	1.45	0.049	0.057
A ₃	0.25		0.01	
b _p	0.36	0.49	0.014	0.019
c	0.19	0.25	0.0075	0.0100
D	4.8	5.0	0.19	0.20
E	3.8	4.0	0.15	0.16
e	1.27		0.050	
H _E	5.80	6.20	0.228	0.244
L	1.05		0.041	
L _p	0.40	1.00	0.016	0.039
Q	0.60	0.70	0.024	0.028
v	0.25		0.01	
w	0.25		0.01	
y	0.10		0.004	
Z	0.30	0.70	0.012	0.028
θ	0°	8°	0°	8°

NOTES:

1. DIMENSIONS D AND E DO NOT INCLUDE MOLD PROTRUSION.
2. MAXIMUM MOLD PROTRUSION FOR D IS 0.15mm.
3. MAXIMUM MOLD PROTRUSION FOR E IS 0.25mm.

Arizona Microtek, Inc. reserves the right to change circuitry and specifications at any time without prior notice. Arizona Microtek, Inc. makes no warranty, representation or guarantee regarding the suitability of its products for any particular purpose, nor does Arizona Microtek, Inc. assume any liability arising out of the application or use of any product or circuit and specifically disclaims any and all liability, including without limitation special, consequential or incidental damages. Arizona Microtek, Inc. does not convey any license rights nor the rights of others. Arizona Microtek, Inc. products are not designed, intended or authorized for use as components in systems intended to support or sustain life, or for any other application in which the failure of the Arizona Microtek, Inc. product could create a situation where personal injury or death may occur. Should Buyer purchase or use Arizona Microtek, Inc. products for any such unintended or unauthorized application, Buyer shall indemnify and hold Arizona Microtek, Inc. and its officers, employees, subsidiaries, affiliates, and distributors harmless against all claims, costs, damages, and expenses, and reasonable attorney fees arising out of, directly or indirectly, any claim of personal injury or death associated with such unintended or unauthorized use, even if such claim alleges that Arizona Microtek, Inc. was negligent regarding the design or manufacture of the part.