

AZ12010

Multiply by 16, 32 Phase-Locked Loop Clock Generator

FEATURES

- Differential Inputs/Outputs for External Voltage Controlled SAW Oscillator
- Optional Internal Crystal Oscillator Driver
- Internal Edge-Matching Phase/Frequency Detector
- Internal Charge-Pump/Integrator Amplifier
- RF Bipolar Design for Low Phase Noise
- Available in a 3x3 mm MLP Package

PACKAGE AVAILABILITY

PACKAGE	PART NO.	MARKING	NOTES
MLP 16 (3x3)	AZ12010AL	AZ12010A <Date Code>	1,2
MLP 16 (3x3) RoHS Compliant / Lead (Pb) Free	AZ12010AL+	AZ12010A+ <Date Code>	1,2
MLP 16 (3x3)	AZ12010BL	AZ12010B <Date Code>	1,2
MLP 16 (3x3) RoHS Compliant / Lead (Pb) Free	AZ12010BL+	AZ12010B+ <Date Code>	1,2
DIE	AZ12010XP	N/A	3

- 1 Add R1 at end of part number for 7 inch (1K parts), R2 for 13 inch (2.5K parts) Tape & Reel.
- 2 Date code format: "YY" for year followed by "WW" for week.
- 3 Waffle Pack

DESCRIPTION

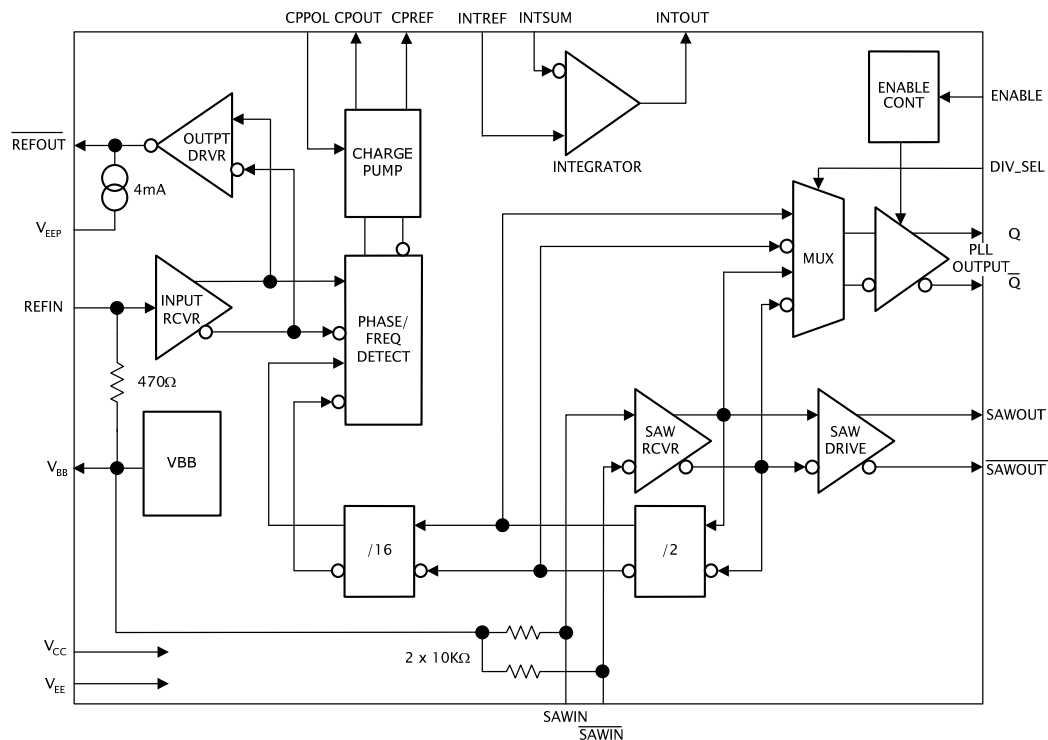

The AZ12010 contains all of the functional elements necessary to implement a Phase-Locked Loop for clock multiplication at frequencies up to 800 MHz. A fixed 32 times multiplication allows the use of low cost crystals or a low frequency reference signal. The output can be divided by two for 16 times net multiplication. The VCISO is differentially or single-ended driven using the chip CML SAW outputs. The dynamic properties of the PLL are under the control of the user through selection of the desired external components.

AZ12010

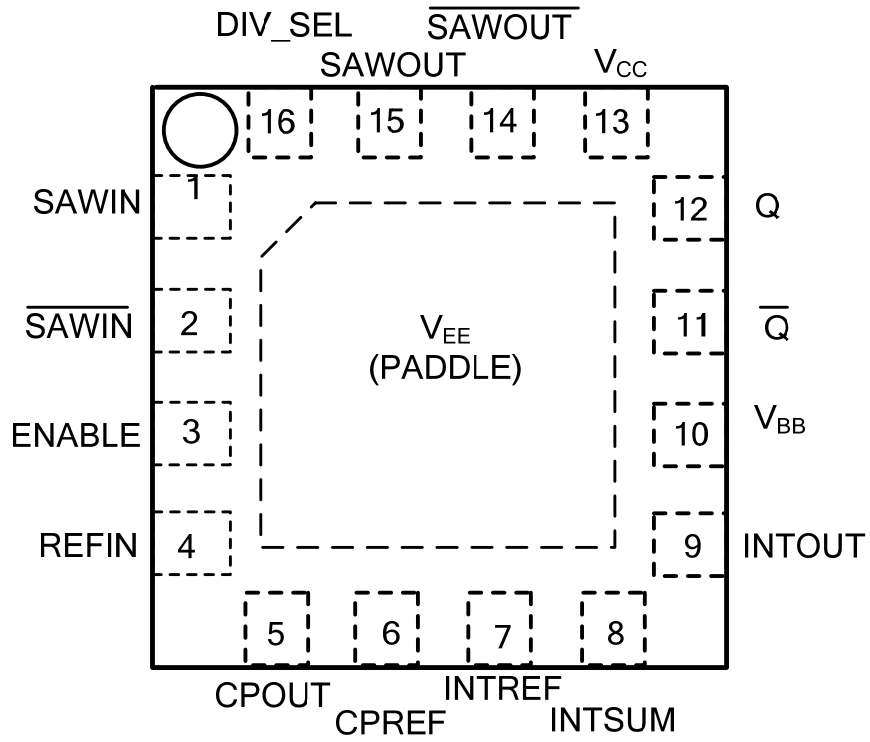

3X3 MLP 16 PACKAGE

AZM12010A: CPPOL pulled High

AZM12010B: CPPOL pulled Low

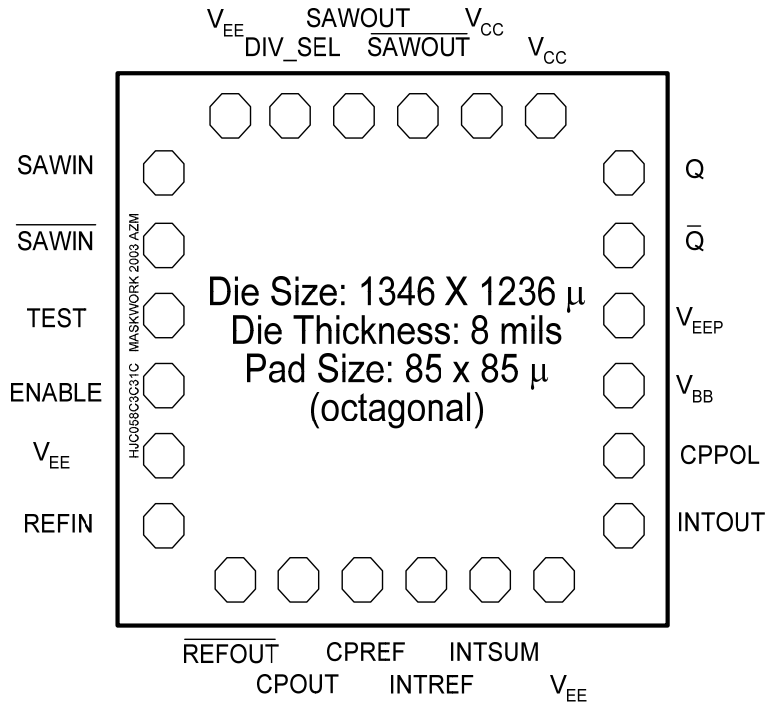

DIE MAP

Pad Center Locations

Signal Name	X coordinate (μ)	Y coordinate (μ)
SAWIN	-522.0	372.3
$\overline{\text{SAWIN}}$	-522.0	220.3
TEST	-522.0	68.3
ENABLE	-522.0	-83.7
V_{EE}	-522.0	-235.7
REFIN	-522.0	-387.7
$\overline{\text{REFOUT}}$	-365.0	-515.8
CPOUT	-213.0	-515.8
CPREF	-61.0	-515.8
INTREF	91.0	-515.8
INTSUM	243.0	-515.8
V_{EE}	395.0	-515.8
INTOUT	552.0	-387.7
CPPOL	552.0	-235.7
V_{BB}	552.0	-83.7
V_{EEP}	552.0	68.3
\overline{Q}	552.0	220.3
Q	552.0	372.3
V_{CC}	395.0	509.9
V_{CC}	243.0	509.9
SAWOUT	91.0	509.9
SAWOUT	-61.0	509.9
DIV_SEL	-219.0	509.9
V_{EE}	-377.0	509.9

AZ12010 FUNCTIONAL PIN/PAD DESCRIPTIONS

Name	Functional Description	Logic Level
REFIN	Reference Frequency Input This pin/pad includes an on-chip 470 Ω pull down resistor to V_{BB} . The input from the reference circuit should be AC coupled.	
$\overline{\text{REFOUT}}$	Reference Frequency Output This pin is an inverted and amplified version of the signal on the REFIN pin. The gain from REFIN to $\overline{\text{REFOUT}}$ is approximately 20. If V_{EEP} is connected to V_{EE} , a 4 ma on-chip current source is provided for the output. $\overline{\text{REFOUT}}$ is not available on the packaged versions (AZ12010A, AZ12010B).	PECL
CPREF	Charge Pump Reference Output The pin/pad voltage is nominally 1.2 volts below V_{CC} .	
CPOUT	Charge Pump Output The charge pump output voltage is $V_{CPREF} \pm 0.3V$ during a phase correction pulse. When there is no correction pulse the output goes high impedance.	
CPPOL	Charge Pump Polarity When this pin/pad is pulled high the PLL operates with a VCSO circuit exhibiting negative pulling slope (the VCSO frequency goes down when the control voltage goes up). When this pin/pad is pulled low (AZM12010B) the PLL operates with a VCSO circuit exhibiting positive pulling slope (the VCSO frequency goes up when the control voltage goes up). If the pin/pad is left open (AZM12010A), an internal pullup resistor selects negative pulling slope mode.	LVC MOS LV TTL
INTREF	Integrator Reference Input This pin/pad should be connected to CPREF through a bias current cancellation network	
INTSUM	Integrator Summing Junction This pin/pad is the summing junction for the integrator amplifier	
INTOUT	Integrator Output	
SAWIN $\overline{\text{SAWIN}}$	SAW Amplifier Inputs If only one input is used (Single-ended VCSO), the unused input should be bypassed with a capacitor to V_{BB} .	
SAWOUT $\overline{\text{SAWOUT}}$	SAW Amplifier Outputs These are open collector outputs for driving the VCSO device. Operating at nominally 9 ma, external pullup resistors must be connected between these pins/pads and V_{CC} . If only one output is used, the other output should be connected to V_{CC} through a 50 Ω resistor.	CML (Analog)
ENABLE	PLL Output Enable The Q and \overline{Q} outputs are enabled when this pin/pad is pulled high. When this pin/pad is low, the Q output is high, and the \overline{Q} output is low. If the pin/pad is left open, an internal pullup resistor enables the outputs.	LVC MOS LV TTL
DIV_SEL	Divide Select When this pin/pad is high, the Q and \overline{Q} outputs are divided by one from the SAW device. When it is low, the Q and \overline{Q} outputs are divided by two from the SAW device. If the pin/pad is left open, an internal pullup resistor selects the divide by one mode.	LVC MOS LV TTL
Q \overline{Q}	Clock Output These pin/pads are the main clock output. When ENABLE is low, the outputs are disabled with Q high and \overline{Q} low.	PECL
V_{BB}	Reference Voltage Output This pin/pad is used to bias the REFIN signal. It must be bypassed externally to the V_{EE} pins/pads with a 0.01 μF capacitor.	
V_{EEP}	REFOUT Current Source If V_{EEP} is connected to V_{EE} , a 4 ma on-chip current source is provided for the $\overline{\text{REFOUT}}$ output. V_{EEP} is not available on the packaged versions (AZ12010A, AZ12010B).	
V_{CC}	Positive Supply +3.0 to +3.6 V	
V_{EE}	Negative Supply Ground	

AZ12010

Absolute Maximum Ratings are those values beyond which device life may be impaired.

Symbol	Characteristic	Rating	Unit
V_{CC}	Power Supply ($V_{EE} = \text{GND}$)	0 to +6.0	Vdc
V_I	Input Voltage ($V_{EE} = \text{GND}$)	0 to +6.0	Vdc
I_{OUT}	PECL Output Current — Continuous — Surge	50 100	mA
T_A	Operating Temperature Range	-40 to +85	°C
T_{STG}	Storage Temperature Range	-65 to +150	°C

AZ12010 DC CHARACTERISTICS ($V_{CC} = +3.0$ to $+3.6$ V, $V_{EE} = \text{GND}$)

Symbol	Characteristic	-40°C		0°C		25°C			85°C		Unit
		Min	Max	Min	Max	Min	Typ	Max	Min	Max	
V_{BB}	Reference Voltage	V_{CC} -1.38	V_{CC} -1.26	V_{CC} -1.38	V_{CC} -1.26	V_{CC} -1.38	V_{CC} -1.31	V_{CC} -1.26	V_{CC} -1.38	V_{CC} -1.26	V
R_{REF}	REFIN Pull-Down resistor to V_{BB}						470				Ω
R_{SAW}	SAWIN, SAWIN Pull-Down resistor to V_{BB}						10K				Ω
V_{HCTL}	High level integrator output	V_{CC} -1.0		V_{CC} -1.0		V_{CC} -1.0			V_{CC} -1.0		V
V_{LCTL}	Low level integrator output		0.5		0.5			0.5		0.5	V
V_{OH}	Output HIGH Voltage ¹ Q, \bar{Q}	V_{CC} -1085	V_{CC} -880	V_{CC} -1025	V_{CC} -880	V_{CC} -1025	V_{CC} -955	V_{CC} -880	V_{CC} -1025	V_{CC} -880	mV
V_{OH}	Output HIGH Voltage ² SAWOUT, SAWOUT	V_{CC} -10	V_{CC}	V_{CC} -10	V_{CC}	V_{CC} -10		V_{CC}	V_{CC} -10	V_{CC}	mV
V_{OL}	Output LOW Voltage ¹ Q, \bar{Q}	V_{CC} -1830	V_{CC} -1555	V_{CC} -1810	V_{CC} -1620	V_{CC} -1810	V_{CC} -1705	V_{CC} -1620	V_{CC} -1810	V_{CC} -1620	mV
V_{OL}	Output LOW Voltage ² SAWOUT, SAWOUT	V_{CC} -349	V_{CC} -481	V_{CC} -365	V_{CC} -516	V_{CC} -392	V_{CC} -449	V_{CC} -557	V_{CC} -465	V_{CC} -661	mV
V_{IH}	Input HIGH Voltage, LVCMOS/LVTTL EN, DIV_SEL	2.2	V_{CC}	2.2	V_{CC}	2.2		V_{CC}	2.2	V_{CC}	V
V_{IL}	Input LOW Voltage, LVCMOS/LVTTL EN, DIV_SEL	0.0	0.8	0.0	0.8	0.0		0.8	0.0	0.8	V
I_{CC} (I_{EE})	Power Supply Current		65		65	45	54	65		65	mA

1. Load is 50Ω to $V_{CC}-2V$
2. Load is 50Ω to V_{CC}

AZ 12010 AC CHARACTERISTICS ($V_{CC} = +3.0$ to $+3.6$ V, $V_{EE} = \text{GND}$)

Symbol	Characteristic	-40°C			25°C			85°C			Unit
		Min	Typ	Max	Min	Typ	Max	Min	Typ	Max	
A_{PD}	Phase Detector Gain					20.3					radians/V
f_{VCO}	External VSCO frequency			800			800			800	MHz
t_r / t_f	Output Rise & Fall Times (20% - 80%) Q, \bar{Q}					120					ps
a_v	SAW Amplifier and Driver Gain at 622.08 MHz ¹	18	24.5	28	15.5	21	24.5	13.5	19	22.5	dB

1. Single Ended Input and Output, Driven from 50Ω backmatched source, Load 50Ω to V_{CC} .

Loop Filter Design

The combination of the phase detector, amplifier, VCO and divider form a second-order phase-locked loop. Proper selection of the loop components is important to obtain stable, low jitter operation.

The loop bandwidth (or natural frequency, ω_n) and damping factor (ζ) are the two major driving forces that define the loop's response to a disturbance. The value of ζ is typically 0.7 to ensure the fastest step response consistent with no ringing. However in many oscillator application ζ may be 3 or higher to provide further phase noise reduction. ω_n is chosen as a compromise between settling time, VCO jitter and reference feedthrough. These values can be computed by the following equations:

$$\omega_n = \frac{1}{N} \sqrt{\frac{K_\phi K_{VCO}}{\tau_1}}$$

$$\zeta = \frac{\tau_2 \omega_n}{2}$$

$$\tau_1 = R_1 C_1$$

$$\tau_2 = R_2 C_1$$

K_ϕ = Phase Detector Gain (20.3 radians/V)

K_{VCO} = VCO Gain (radians/sec/volt)

N = Frequency Divisor value (32)

The component definitions are shown in the figure below. R3 should be equal to R1 to minimize integrator offsets.

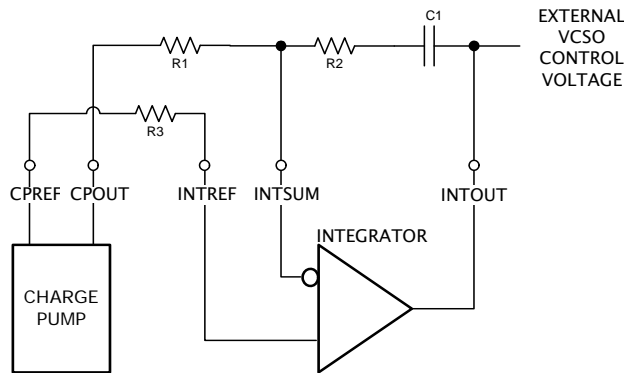

Figure 1 Charge Pump and Integrator

Application Circuit

A typical application circuit is shown in Figure 2.

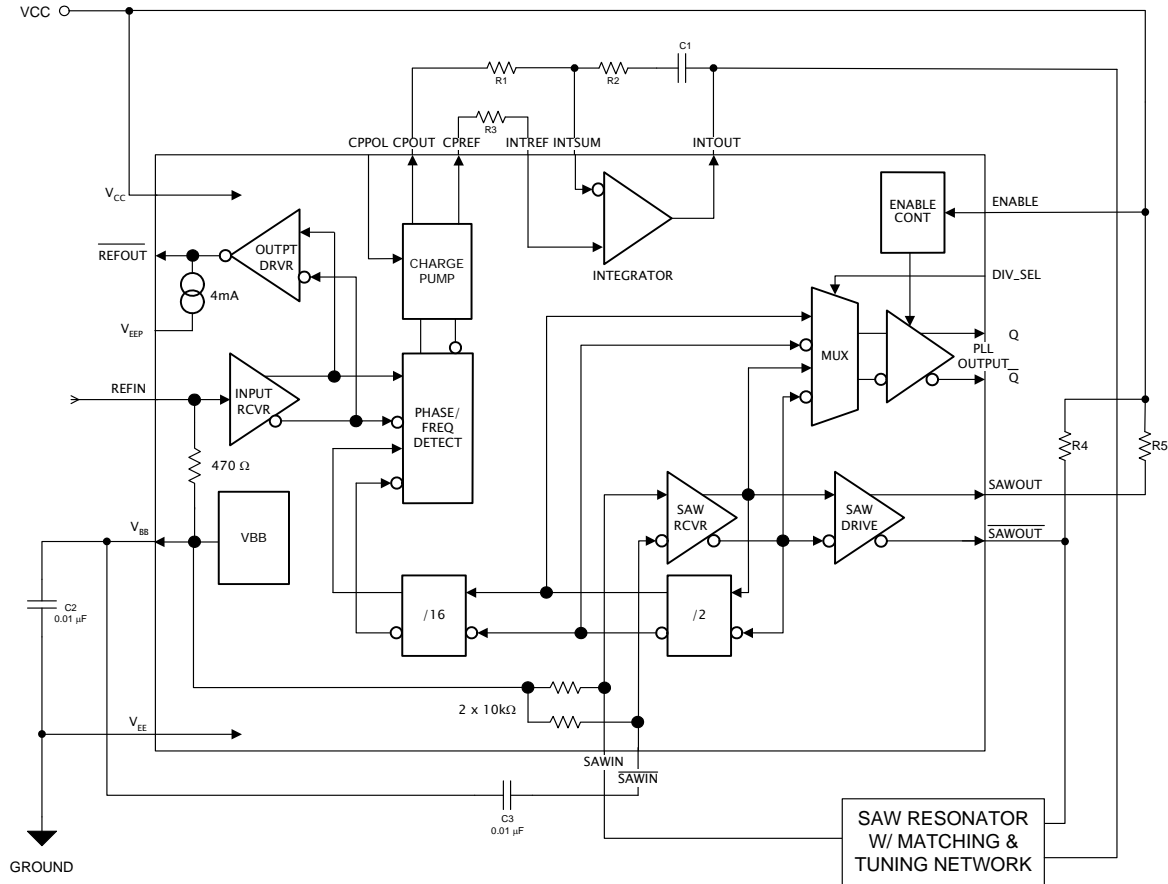
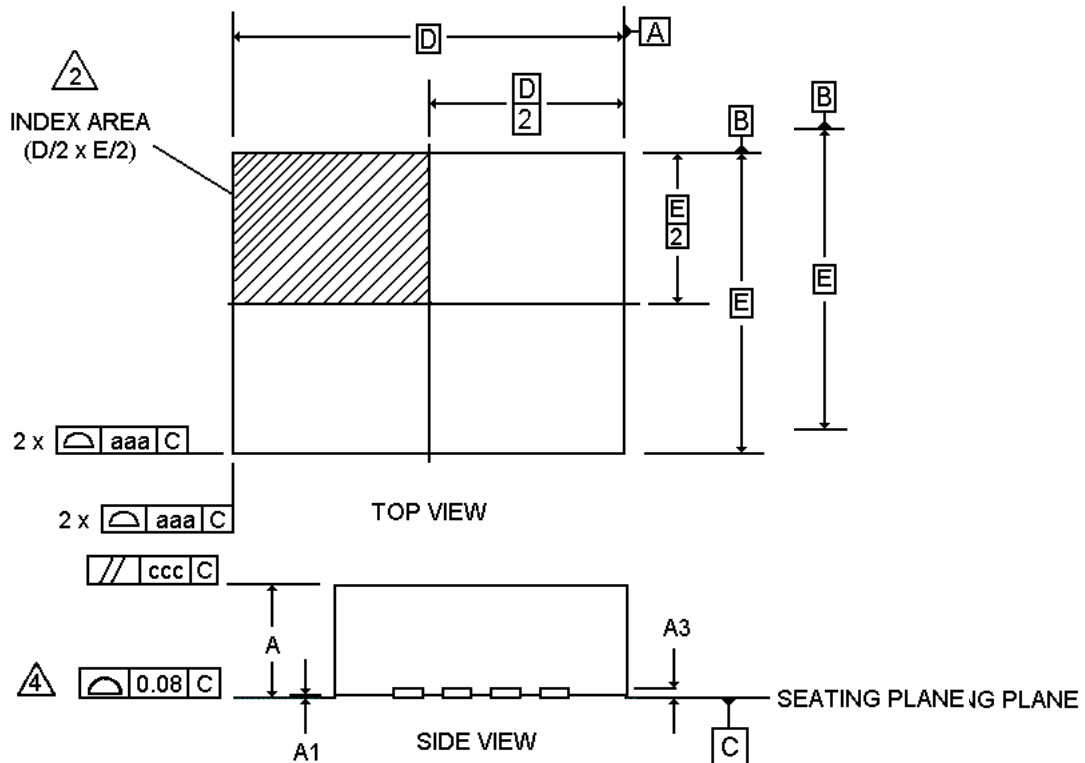

Figure 2. Typical Application, Always Enabled and Divide by One for Output

**PACKAGE DIAGRAM
MLP 16**



NOTES

NOTES

1. DIMENSIONING AND TOLERANCING CONFORM TO ASME T14-1994.
2. THE TERMINAL #1 AND PAD NUMBERING CONVENTION SHALL CONFORM TO JESD 95-1 SPP-012.
3. DIMENSION *b* APPLIES TO METALLIZED PAD AND IS MEASURED BETWEEN 0.25 AND 0.30mm FROM PAD TIP.
4. COPLANARITY APPLIES TO THE EXPOSED PAD AS WELL AS THE TERMINALS.

DIM	MILLIMETERS	
	MIN	MAX
A	0.80	1.10
A1	0.00	0.05
A3	0.25 REF	
<i>b</i>	0.225	0.275
D	2.90	3.10
D2	1.65	1.95
E	2.90	3.10
E2	1.65	1.95
<i>e</i>	0.50 BSC	
L	0.35	0.45
aaa	0.25	
bbb	0.10	
ccc	0.10	

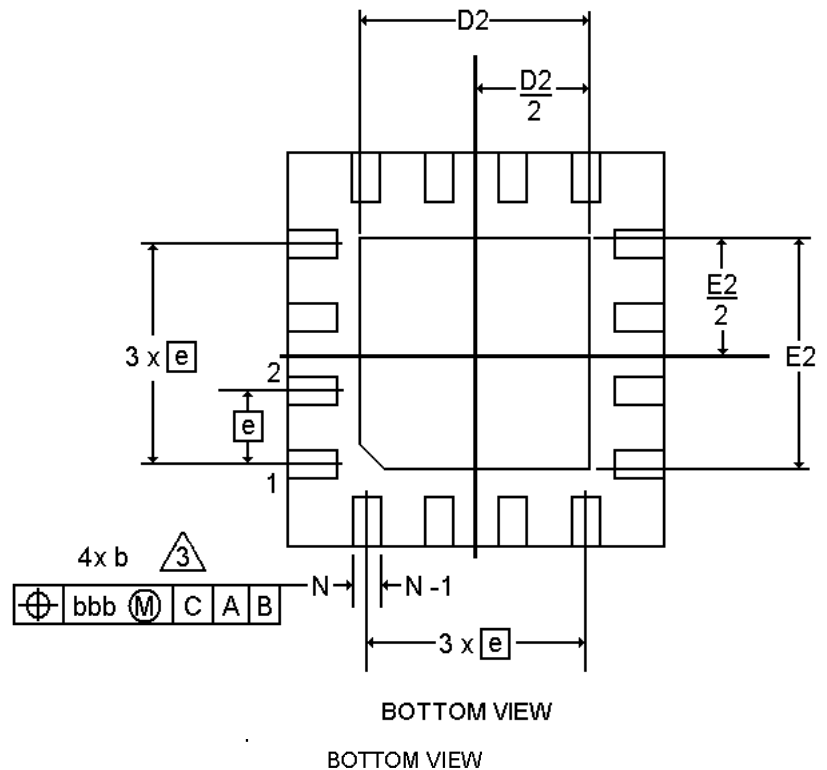

Arizona Microtek, Inc. reserves the right to change circuitry and specifications at any time without prior notice. Arizona Microtek, Inc. makes no warranty, representation or guarantee regarding the suitability of its products for any particular purpose, nor does Arizona Microtek, Inc. assume any liability arising out of the application or use of any product or circuit and specifically disclaims any and all liability, including without limitation special, consequential or incidental damages. Arizona Microtek, Inc. does not convey any license rights nor the rights of others. Arizona Microtek, Inc. products are not designed, intended or authorized for use as components in systems intended to support or sustain life, or for any other application in which the failure of the Arizona Microtek, Inc. product could create a situation where personal injury or death may occur. Should Buyer purchase or use Arizona Microtek, Inc. products for any such unintended or unauthorized application, Buyer shall indemnify and hold Arizona Microtek, Inc. and its officers, employees, subsidiaries, affiliates, and distributors harmless against all claims, costs, damages, and expenses, and reasonable attorney fees arising out of, directly or indirectly, any claim of personal injury or death associated with such unintended or unauthorized use, even if such claim alleges that Arizona Microtek, Inc. was negligent regarding the design or manufacture of the part.